



TELSMITH

TELSMITH
an Astec company

P.O. Box 539
Mequon, WI 53092-0539

Phone: 800-765-6601
262-242-6600
Fax: 262-242-5812

www.telsmith.com
sales@telsmith.com

©2010 Telsmith, Inc.
Impact Crusher 02-10

TELSMITH an Astec Industries Company

10910 N. INDUSTRIAL DR • MEQUON, WI 53092 USA • 262.242.6600 FAX 262.242.5812 • telsmith.com



TELSMITH

an Astec company



TELSMITH

PA6060

**HORIZONTAL SHAFT
IMPACT CRUSHERS**



THE TELSMITH DIFFERENCE:

Telsmith offers a full line of horizontal shaft impact crushers with models specifically designed to serve industries ranging from heavy duty aggregate processing, to recycling asphalt and concrete products, to 24 hour mining operations. Included are Primary Andreas (PA) models, Primary New Holland (NH) models and secondary Andreas (HSI) models.

As a part of the Telsmith difference, each impact crusher incorporates value that goes well beyond the basic machinery.

- **Expertise:** Application engineers listen to your challenges and apply their experience and expertise to develop solutions that work.

- **Innovative Solutions:** Incorporating input from customers and utilizing modern design tools, Telsmith engineers develop reliable equipment with unique cost saving features.

- **Quality:** Manufacturing craftsmen combine the discipline of an ISO 9001: 2008 environment with precision CNC machining and skilled master welders. All Telsmith equipment goes through rigorous testing prior to shipping to ensure it measures up to the Telsmith standard.

- **Parts Availability:** Large parts inventories and people who know the machines are in place to ensure a quick, knowledgeable response. We are available to will work with you 24 hours a day, seven days a week.

- **Field Service:** On-site service comes from a team of technical specialists ready to respond to a downtime emergency anywhere in the world.

- **Training:** On-site training and factory based (hands on) seminars are available to assist your staff in achieving optimum performance.

- **Integrity:** A core value of Telsmith, integrity penetrates all that we do. Quality equipment, world class support and honest business practices are what you can expect from Telsmith.

CONTENTS



Primary Andreas (PA) Models:

Pages 3 to 6

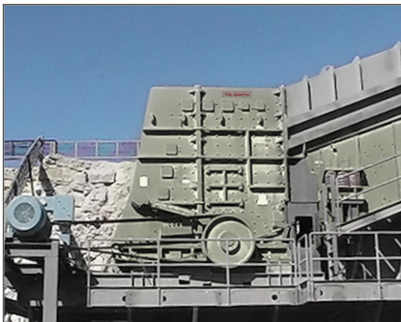

Primary New Holland (NH) Models:

Pages 7 to 10



HSI (secondary Andreas) Models:

Pages 11 to 14

PA MODELS

Designed as a primary crusher for either quarried stone or recycling concrete, Telsmith PA crushers offer advanced features to deliver dependable, low maintenance, high performance primary crushing.

Solid Rotor: A massive, solid-type, sculpted rotor provides the most durable solution, delivering performance and lower maintenance costs. The extra weight and high inertia allow PA crushers to consistently and reliably crush up to 40" (1020 mm) feed.

Hydraulic Adjustment: Hand-held controls work with hydraulic cylinders and position sensors to give operators the luxury of changing the setting in moments.

Hydraulic Relief with Auto Reset: Protecting the crusher from damage and expensive repairs, the hydraulic relief

system will automatically open the setting when uncrush-able materials impact the apron. Once the material has passed through the crusher, the auto reset automatically returns the apron to the pre-set position, allowing uninterrupted crushing and greater production.

Hydraulic Tilting Feed Plate: Occasional bridging can occur in any impact crusher. Incorporating a hydraulic tilting feed plate, the PA crusher allows operators, using handheld controls, to clear the jam-up quickly and safely, without shutting down.

Telsmith Primary Andreas impact crushers are versatile and can be mounted on track or wheeled portable units or onto fixed structures with truck dump hoppers. Built heavy with advanced operating features, PA crushers deliver consistent, reliable production with lower operating costs than other brands.



PA SECTION VIEW:

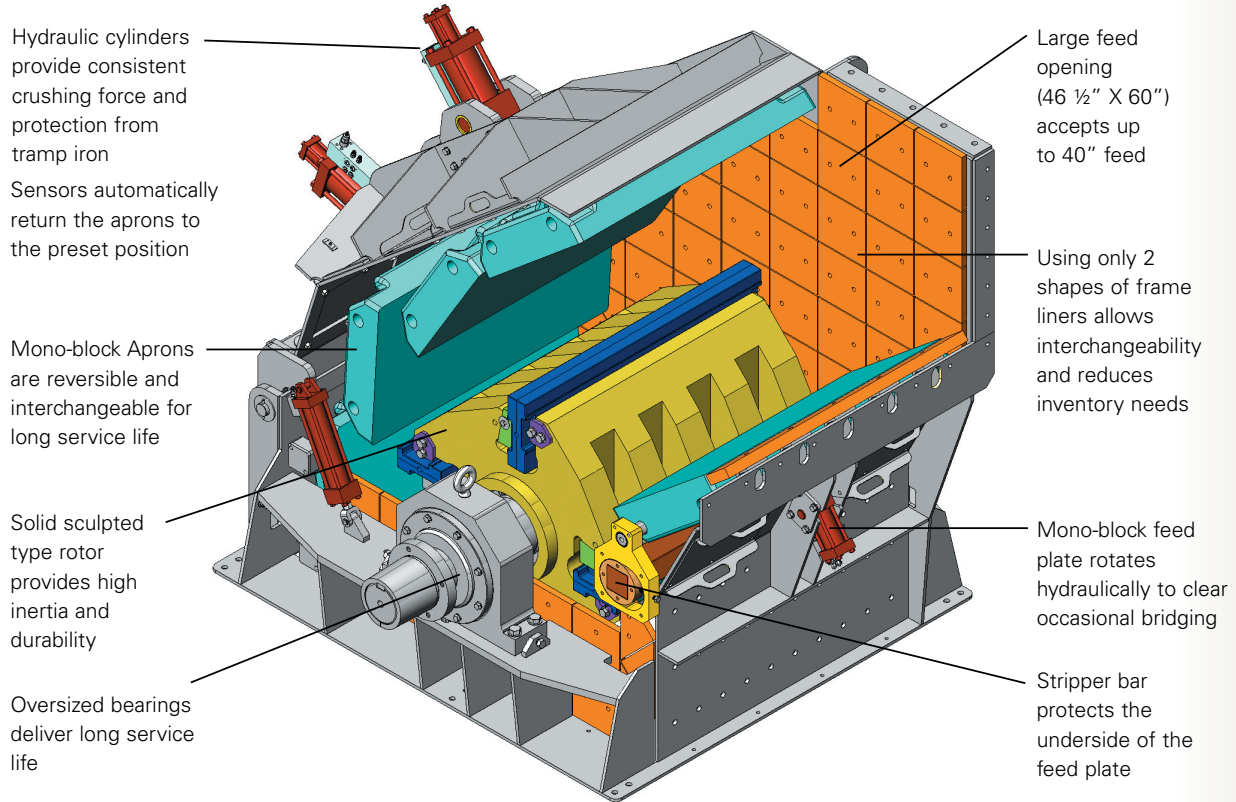

RUGGED SOLID TYPE ROTOR:

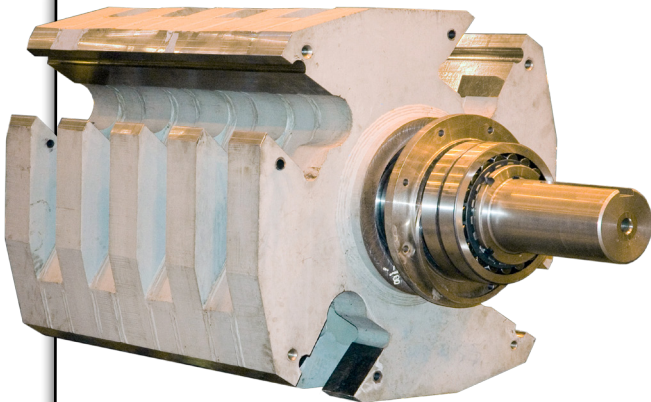

A massive solid type sculptured rotor delivers both high inertia for optimum crushing performance and solid backing support for the blow bars. This result is longevity and lower costs, even in rugged primary crushing.



Blow bars are held firmly in place with a locking wedge design. The blow bar is designed for 3 rotations allowing up to 4 wear surfaces.

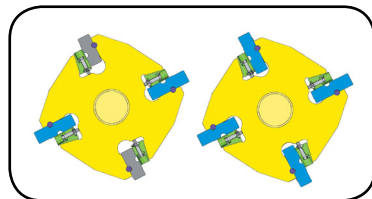

2 & 4 bar arrangements optimize performance in a variety of applications.

HYDRAULIC ADJUST AND RELIEF:

Hydraulic Adjustment and Relief provide multiple benefits for operations and maintenance.

- Quick adjustment allows operators to maintain optimum production without suffering downtime.
- Hydraulics provide a more secure positioning of the apron than gravity hung aprons, yielding greater control over product sizing.
- Tramp Iron Relief protects the crusher from damage while sensors automatically reset the apron to allow uninterrupted production.
- Handheld controls keep the operator and maintenance at a safe distance.



ADVANCED HYDRAULICS

Hydraulic cylinders secure the apron into position, provide quick adjustment and deliver overload protection resulting in lower operating costs and greater annual production.



HANDHELD CONTROLS

Handheld controls provide simple use of all hydraulic functions (frame open/close, upper and lower apron adjustment, feed plate tilt up/down, manual and auto mode) and allow operators to maintain a safe distance when adjusting the crusher or clearing jam-ups.

HYDRAULIC TILT FEED-PLATE:

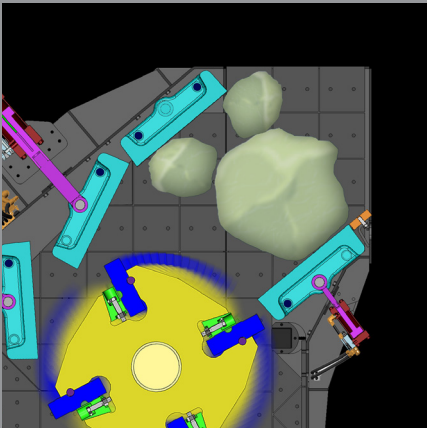

1) Occasionally, multiple pieces of material can become bridged or jammed in the feed opening. Traditional methods for clearing the jam required risky procedures and extensive downtime.

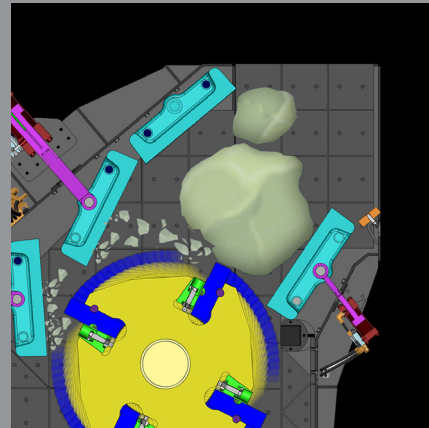

2) PA crushers are equipped with a hydraulic tilting feed plate. Remaining at a safe distance, the operator uses the handheld controller to tilt the plate, freeing the stone. Crushing operations can resume immediately.

PA6060 DIMENSIONS:

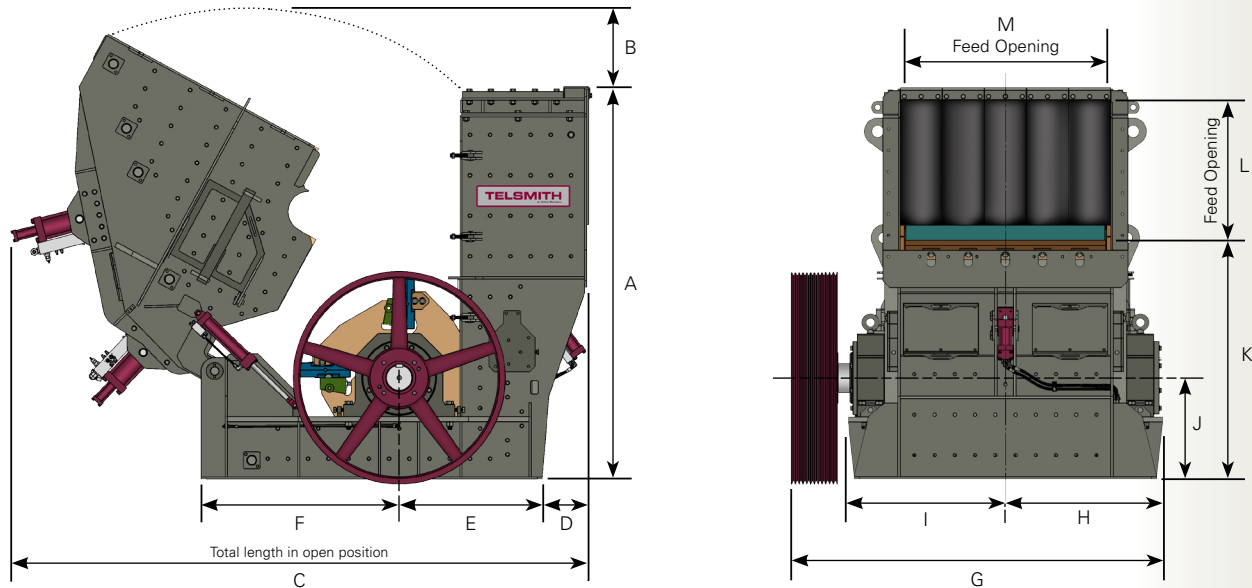

General Dimensions - Models PA6060, PA6480

		A	B	C	D	E	F	G	H	I	J	K	L	M
PA6060	US (in)	106	11	170.5	13.25	42.5	58.75	109.5	46.5	46.75	30	71	48	60
	mm	2,693	279	4,331	337	1,080	1,492	2,781	1,181	1,187	762	1,803	1,219	1,524
PA6478	US (in)	131	12.5	191	15	44.5	60.5	148.25	56.75	56.75	32.75	75.5	48.5	80
	mm	3,327	318	4,851	381	1,130	1,537	3,766	1,441	1,441	832	1,918	1,232	2,032

General Specifications

	PA6060		PA6480	
	US	Metric	US	Metric
Total Weight	61,000 Lbs	27,700 Kg	92,000 Lbs	41,731 Kg
Recommended Motor	400 to 500 HP	300 to 375 Kw	600 to 700 HP	448 to 522 Kw
Recommended Crusher RPM Range	360 to 675 RPM		335 to 400 RPM	
Rated Capacity	350 to 600 STPH	315 to 645 MTPH	400 to 800 STPH	364 to 728 MTPH
Feed Opening	46.5" x 60"	1,181 mm x 1,524 mm	48.5" x 80"	1,234 mm x 2,032 mm
Max Feed Size	40"	1,016 mm	40"	1,016 mm
Rotor Size	59" x 59"	1,500 mm x 1,500 mm	64" x 79"	1,626 mm x 2,007mm
Rotor Weight Assembled	27,800 Lbs	12,600 Kg	43,000 Lbs.	19,504 Kg
Moment of Inertia	48,330 Lbs.·Ft ²	2,042 Kg·m ²	88,500 Lbs.·Ft ²	3,740 Kg·m ²
Blow Bars	4 Rows With One Bar Per Row		4 Rows With One Bar Per Row	
Blow Bar Thickness	4.5"	114 mm	4.75"	121 mm
Blow Bar Weight	1,050 Lbs	477 Kg	1,550 Lbs.	703 Kg
Mono-block Apron Weight	2,500 Lbs	1,136 Kg	3,500 Lbs.	1,588 Kg
# of side liner shapes	2	2	2	2
Side Liner Thickness	1.25"	32 mm	1.25"	32 mm
Side Liner Material	AR 400	AR 400	AR 400	AR 400
Bearing Size	220 mm - Wide Series		260 mm - Wide Series	
Shaft diameter @ Rotor	11.8"	300 mm	14.2"	360 mm
Hydraulic Tank Capacity	10 Gallons	38 Liters	10 Gallons	38 Liters
Hydraulic Motor	7 1/2 HP	5.6 Kw	7 1/2 HP	5.6 Kw

PA MODELS

NH Models (NH4246, NH4856, NH6071) are high performance New Holland style Primary Impact crushers. Equipped with a solid rotor and large volume impact chamber, these designs are well suited for high production crushing of softer, low abrasion materials

With the Largest explosion chamber in the industry, these crushers have capacities of up to 2,100 TPH. An adjustable breaker bar controls production sizes ranging from 2" x0 to 8" x 0Del ut atis ad ecte dit la faci blandre riurerostrud del NH Models (NH4246, NH4856, NH6071) are high performance New Holland style Primary Impact crushers. Equipped with a solid rotor and large volume

impact chamber, these designs are well suited for high production crushing of softer, low abrasion materials

With the Largest explosion chamber in the industry, these crushers have capacities of up to 2,1000 TPH. An adjustable breaker bar controls production sizes ranging from 2" x0 to 8" x 0Del ut atis ad ecte dit la faci blandre riurerostrud del



NH SECTION VIEW:

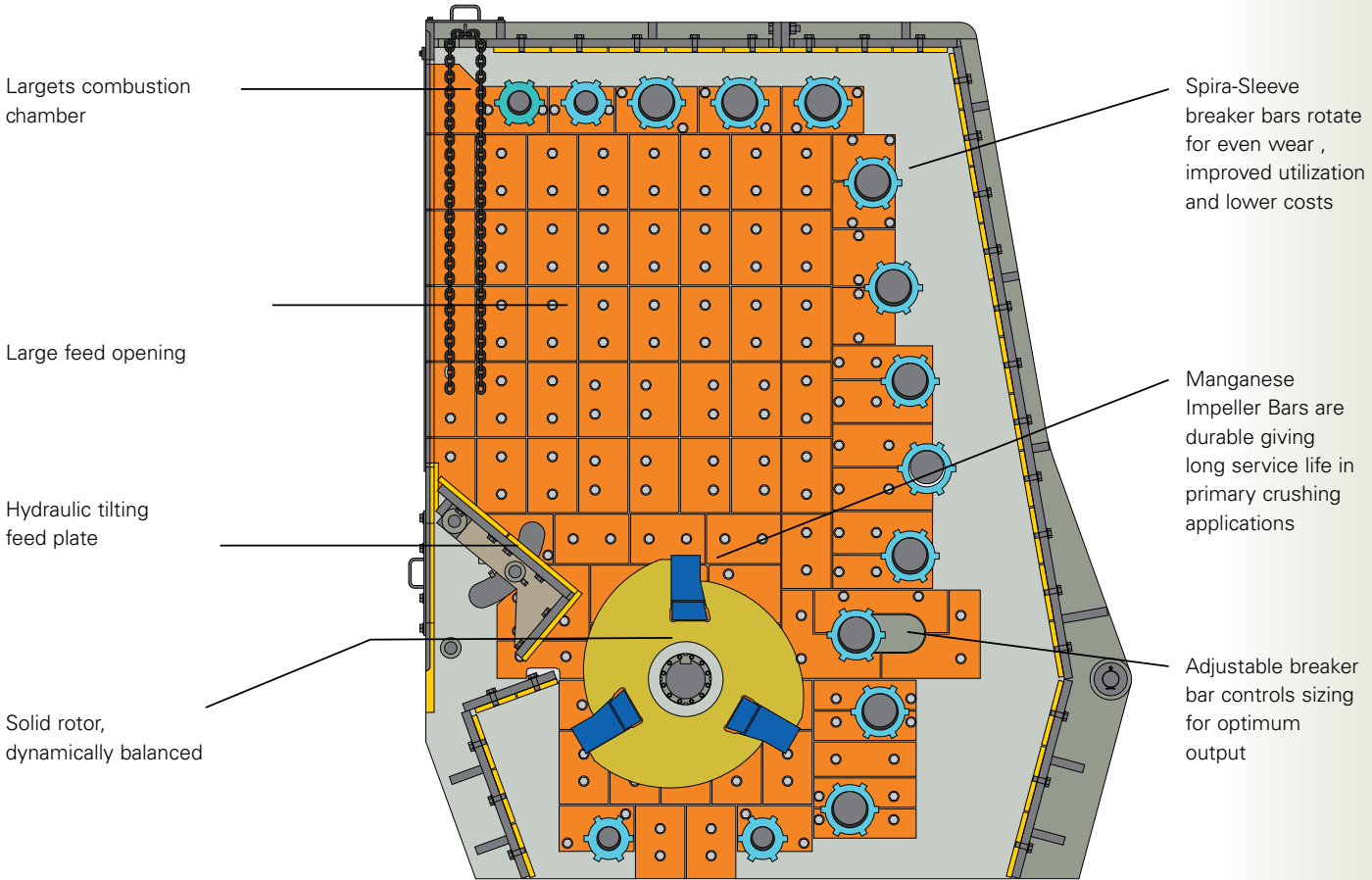

NH FEATURES

HYDRAULIC TILT PLATE:

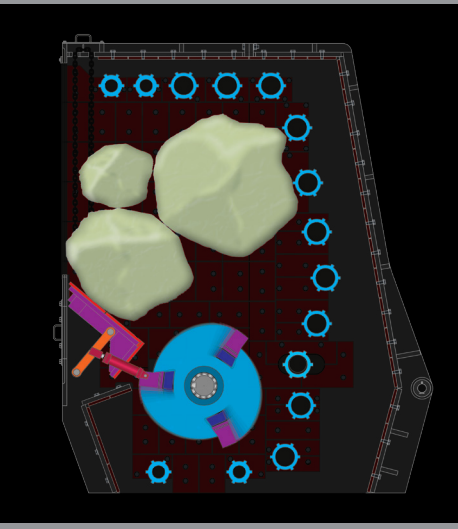

MONO-BLOCK APRONS are reversible and interchangeable for long service life. They are designed for durability and efficiency in primary crushing applications.

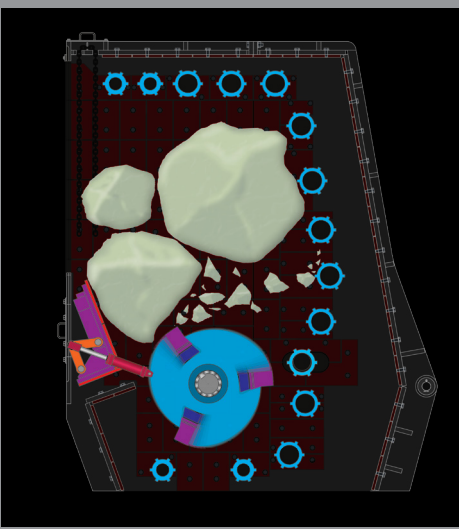

MONO-BLOCK APRONS are reversible and interchangeable for long service life. They are designed for durability and efficiency in primary crushing applications.

RUGGED SOLID TYPE ROTOR:

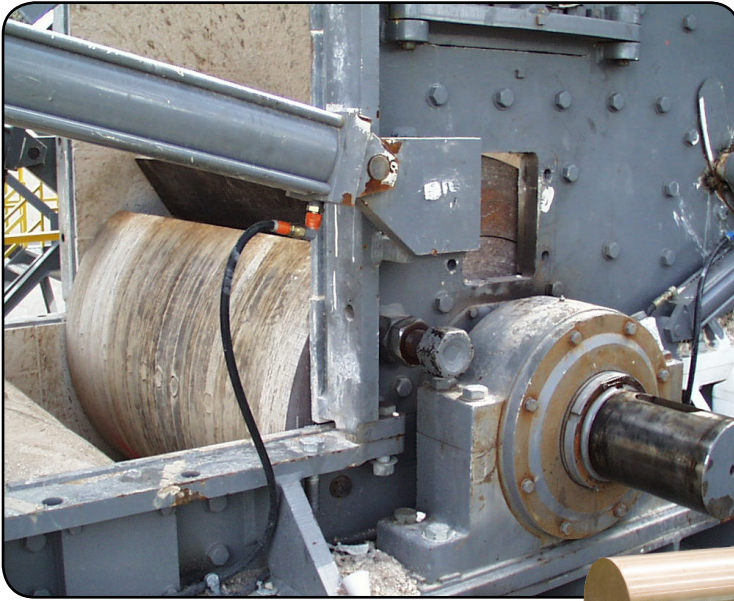

A massive solid type sculptured rotor delivers both high inertia for optimum crushing performance and solid backing support for the blow bars. This results in longevity and lower costs, even in rugged primary crushing. A massive solid type sculptured rotor delivers both high inertia for optimum crushing performance and solid backing support for the blow bars. This results in longevity and lower

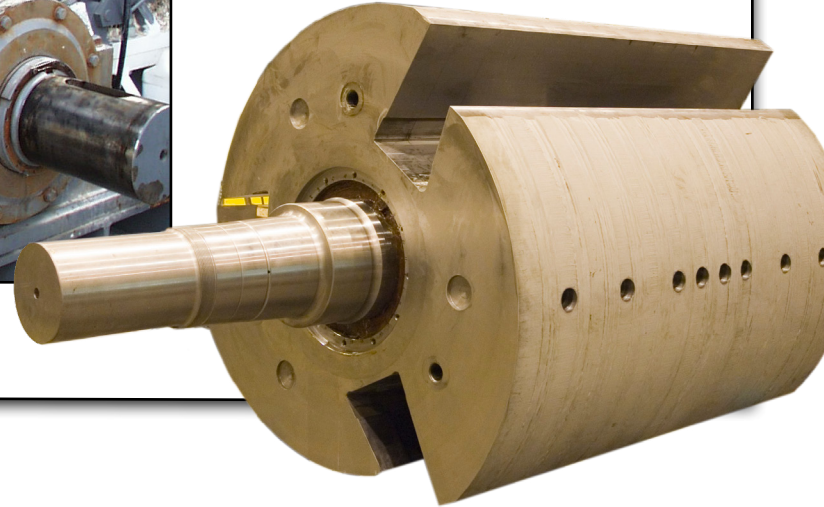

General Specifications

Units	US	Metric	US	Metric	US	Metric
Model	4246		4856		6071	
Total Weight	59,500 Lbs	26,990 Kg	94,170 Lbs	42,715 Kg	195,000	88,450 Kg
Recommended Hp	300 - 500 Hp	224 - 375 Kw	400-700 Hp	300 - 525 Kw	800 - 1500 Hp	600 - 1120 Kw
RPM Range	480 - 770		420 - 700		330 - 540	
Rotor Tip Speed Range						
Rated Capacity	250 - 600 TPH		600 - 1,000 TPH		1,000 - 2,100 TPH	
Feed Opening	46" x 59 3/4"	1,170 x 1,520 mm	56" x 85"	1,425 x 2,160 mm	71" x 100 1/2"	1,805 x 2,555 mm
Max Feed Size	36"	914 mm	46"	1,168 mm	56"	1,422 mm
Rotor Size	38" x 45"	965 x 1,143 mm	43" x 55"	1,092 x 1,397 mm	57" x 70"	1,448 x 1,778 mm
Rotor Weight Assembled	12,190 Lbs	5,530 Kg	22,970 Lbs	10,420 Kg	42,080 Lbs	19,090 Kg
Moment of Inertia	17,630 Lb.Ft ²		40,620 Lb.Ft ²		128,050 Lb.Ft ²	
Blow Bars	2		2		3	
Blow Bar Thickness	45"	1,143 mm	55"	1,397 mm	70"	1,778 mm
Blow Bar Weight	460 Lbs	210 Kg	922 Lbs	418 Kg	1,621 Lbs	735 Kg
Side Liner Thickness	1 1/4"	32 mm	1 1/2"	38 mm	1 1/2"	38 mm
Side Liner Material	Manganese Steel & Abrasion Resistant Steel					
Bearing Type						
Bearing Size						
Shaft diameter @ Rotor						
Shaft diameter @ sheave	5 1/2"	140 mm	5 1/2"	140 mm	9 1/2"	241 mm
Hydraulic Tank Capacity						
Hydraulic Motor						

NH SIZE AND MODEL CHARTS:

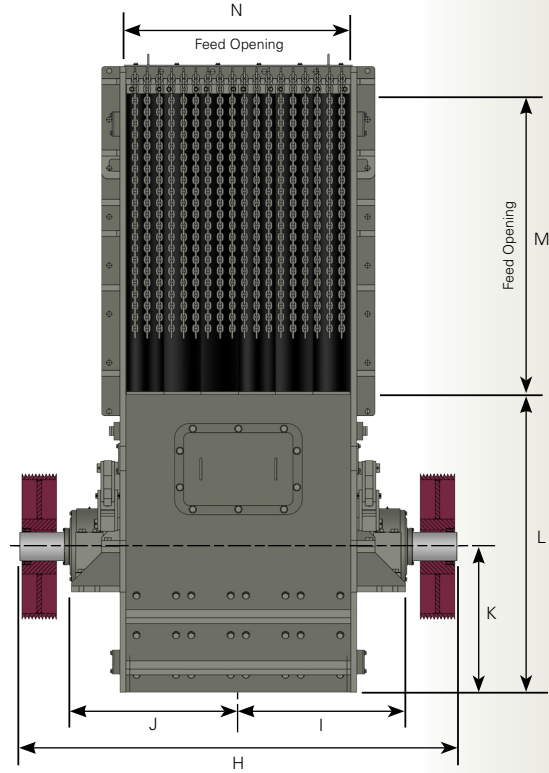
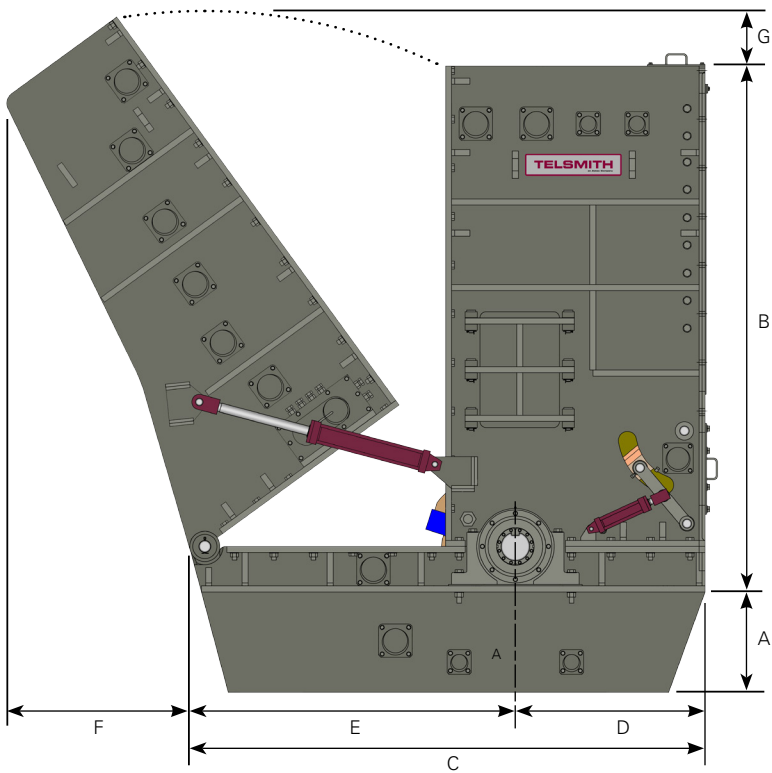

Note: Dimensions are approximate, rounded to the nearest 1/4"

General Dimensions - Models 4224,4856,6071

Model		A	B	C	D	E	F	G	H	I	J	K	L	M	N
4246	US (in)	137.5	42	67.5	43.5	111	131	55.75	37.25	111.5	35.25	30	19.75	48	59.5
	mm	3490	1068	1715	1105	2819	3327	1417	946	2835	895	762	502	1219	1511
4856	US (in)	183	48.25	88	51	139	171.5	60.75	45.75	121.5	47.5	33.25	17.75	58.5	98.75
	mm	4649	1128	2235	1295	3531	4356	1543	1162	3086	1213	845	451	1486	2508
6071	US (in)	220.75	80.25	107.25	62.5	169.75	210	71.25	52	142.5	48	48	32.75	71.5	101.25
	mm	5606	2040	2724	1588	4312	5337	1810	1321	3620	1219	1219	833	1816	2573

HSI MODELS

SECONDARY HSI



TelSmith HS models (HS2421, HS2430, HS3036, HS4230, HS5252, HS5263) are Andreas style impact crushers designed for secondary crushing. Efficient open style rotors and heavy - gravity hung aprons deliver consistent performance when crushing aggregates or recycled asphalt products (RAP) Udemque inpra moenica mei pra? Nihilii spero cresuam inum sciem dit, coenatum publi idi, cute pritam renterum imorbis se tanum oriam quodiam iam co ubis, peceri percereses, consuli condie ad fur. At publius? Fue finum hil tati trio te con ignost? Ibussimis es! Viri sent, sen in vid inaturnime furoxim isules C. Es vertam ommodis orus faciem cultum nihilin Itas et L. Simovivatus re rei peres cotimil icaudene faciem nontemlque nes! Hilis, oculus publi

interri mulostium di, opublis facchus, clatide int Catum inam a morus, pulic in vid dienhin vit, num periores endi incla nox maiocus virioni natqua rendem nonerni rideper escrum culium caed niuum utus? Ebemus co atuus mo pero, Catquodio, C. Fectum atus. Maricae ca omne abus vit accessen atilici teatqui deliae nones verum ina, meis Cat, Ti. Omnest? que aderrime nonvocut abus efendum ultius vo, Cupiessesula deo et faccis.

Ore tides erei public mantratus trei por hors bon simoltiam atu straedo, utum ius inihi, quam, teatis. Lut graris tebus vicaesilibus larit, se que ta, sil halius hos med nori se atiemor quam intiamdiis. To cae, qua

HSI SECTION VIEW:

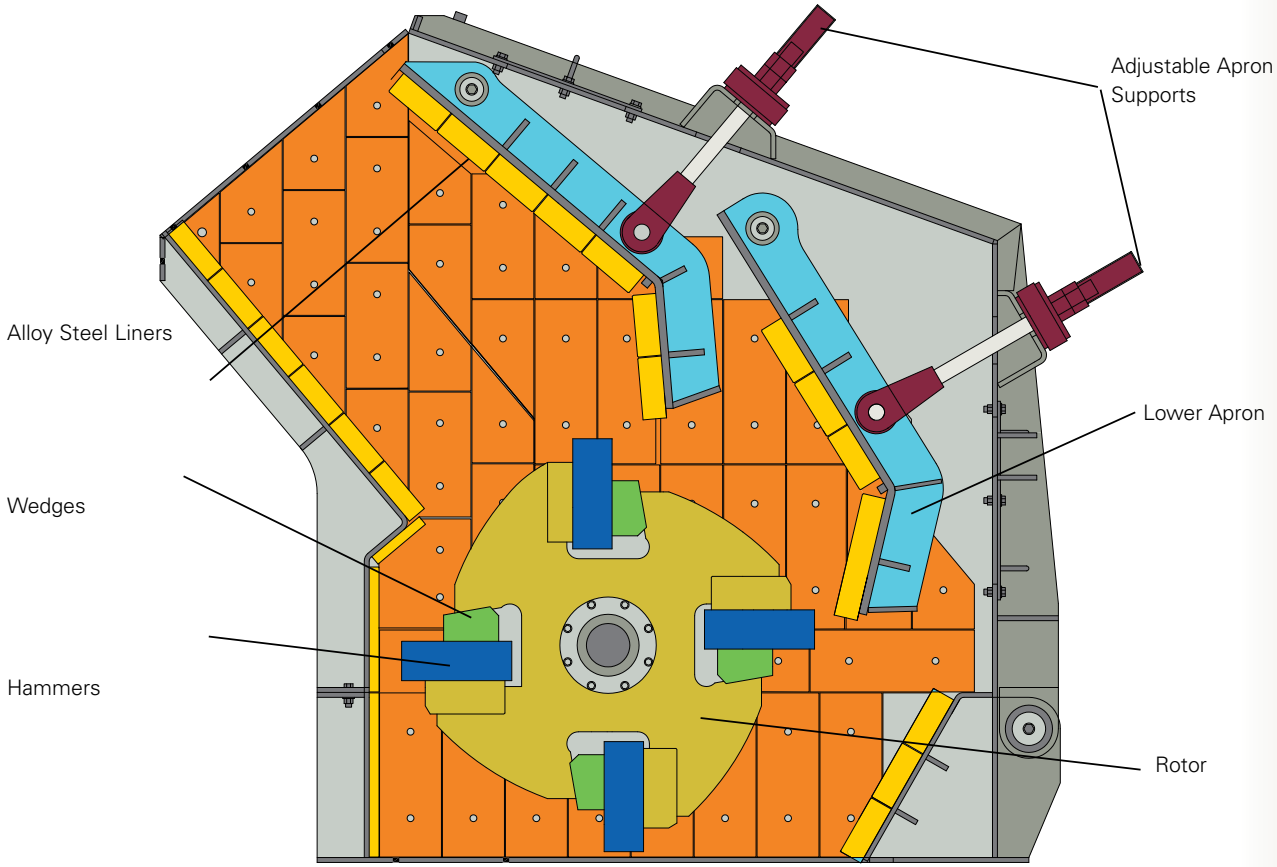

HSI ROTOR DESIGN:

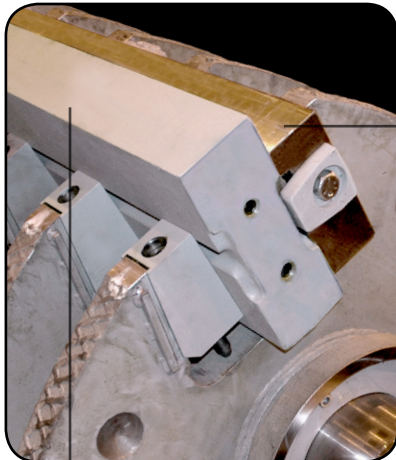

Blow bars are held firmly in place with a locking wedge design. The blow bar is designed for 3 rotations

Blow bars are held firmly in place with a locking wedge design. The blow bar is designed for 3 rotations allowing up to 4 wear surfaces.

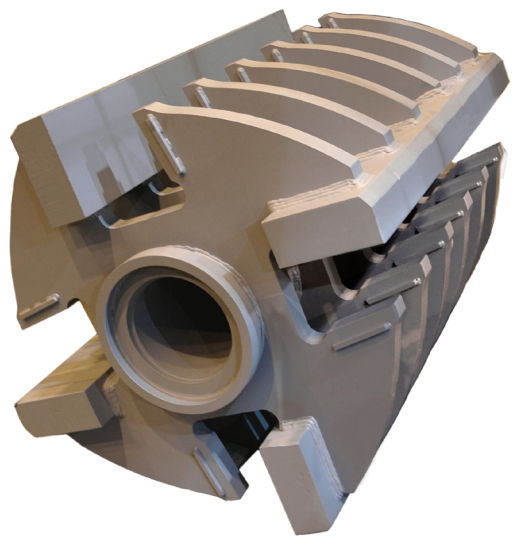

A massive solid type sculptured rotor delivers both high inertia for optimum crushing performance and solid backing support for the blow bars. This results in longevity and lower costs, even in rugged primary crushing.

HSI FEATURES & SPECIFICATIONS:



INSPECTION DOORS

Inspection doors are located on both sides of the PA6060, allowing quick and easy access.

INSPECTION DOORS

Inspection doors are located on both sides of the PA6060, allowing quick and easy access.

HSI Specifications												
	US	mm	US	mm	US	mm	US	mm	US	mm	US	mm
Model	2421		2430		3036		4230		5252		5263	
Total Weight	3,170 Lbs	1,440 Kg	3,500 Lbs	1,590 Kg	7,300 Lbs	3,310 Kg	19,250 Lbs	8,730 Kg	37,500 Lbs	17,000 Kg	48,000 Lbs	21,775 Kg
Recommended HP	50		75		75-100		75-100		250-300		300-400	
Crusher Sheave Options (P.D)	20"	508 mm			21.2"	546 mm	30"	762 mm	40"	1,016 mm	40"	1,016 mm
Recommended Crusher RPM Range	1200		1200		1200		1200		1200		1200	
Rotor Tip Speed Range												
Rated Capacity	35 -50 TPH				75 - 100 TPH		80 - 120 TPH		110 - 230 TPH		190 - 320 TPH	
Feed Opening	11" x 22"	280 x 560 mm	13" x 31"	330 x 787mm	17" x 36"	432 x 915 mm	16" x 31"	406 x 787 mm	24" x 43"	610 x 1,092 mm	24" x 64"	610 x 1,625 mm
Max Feed Size	5"		7"		9"		12"		16"		16"	
Rotor Size			24" x 29"		610 x 737 mm							
Rotor Weight Assembled	1035 Lbs	470 Kg	1051 Lbs	480 Kg			5,045 Lbs	2,290 Kg	10,625 Lbs	4,820 kg	11,630 Lbs	5,275 Kg
Moment of Inertia												
Blow Bars	2		2		2		4		4			
Blow Bar Thickness												
Blow Bar Weight	120 Lbs	55 Kg										
Side Liner Thickness	1/2"	13 mm	1/2"	13 mm	1/2"	13 mm	1 1/4"	32 mm	1 1/4"	32 mm	1 1/4"	32mm
Side Liner Material	Chrome Alloy											
Bearing Type												
Bearing Size												
Shaft diameter @ Rotor												
Shaft diameter @ sheave												
Hydraulic Tank Capacity												
Hydraulic Motor												

HSI SIZE AND MODEL CHARTS:

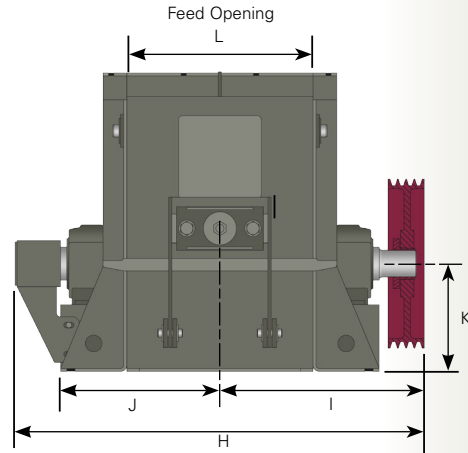
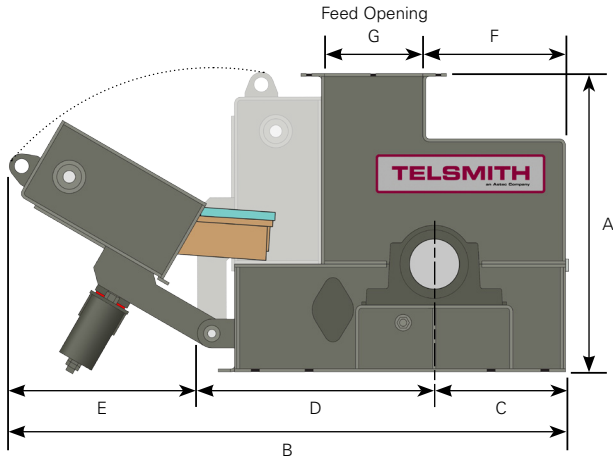

General Dimensions - Models 2421, 2430

Model		A	B	C	D	E	F	G	H	I	J	K	L
2421	US (in)	37	25.75	24	15.75	45.5	36	24.75	19.25	49.5	13	21.5	16
	mm	940	655	613	403	1154	914	627	489	1256	330	546	406
2430	US (in)	37	26.75	24.5	16.25	58.75	36	32.75	23.75	56.5	13	30.5	16.25
	mm	940	681	622	413	1492	914	832	603	1434	330	775	413

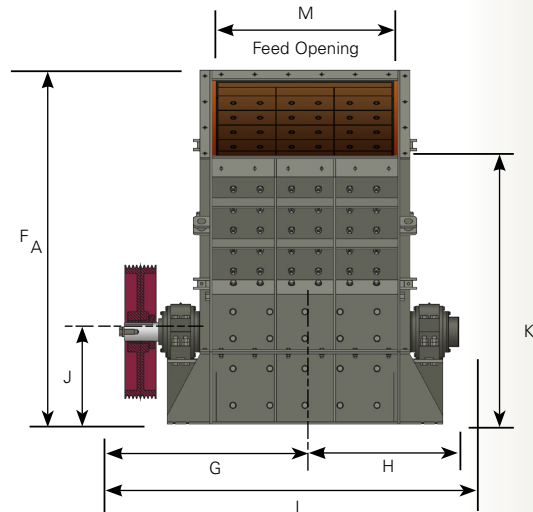
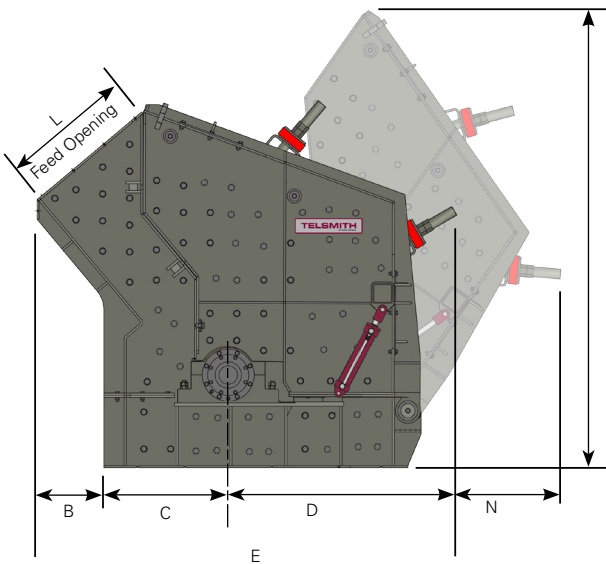

General Dimensions - Models 3036, 3048, 4230, 5252, 5263

Model		A	B	C	D	E	F	G	H	I	J	K	L	M	N
3036	US (in)	71.25	12.5	18.5	28.25	81.25	61.75	34.25	26.75	68.5	17	42.5	17	36.5	45
	mm	1811	321	473	718	2065	1567	870	676	1740	432	1078	435	927	1140
3048	US (in)	77	3.5	20.75	29.5	76.5	72.75	39.75	37	76.75	20.25	41.5	17.75	47.75	39
	mm	1956	89	529	751	1943	1848	1011	940	1950	514	1054	452	1213	992
4230	US (in)	108	13.5	32	45.5	77.25	83.5	38	28.5	76	23.25	58	16	31	44
	mm	2743	343	810	1156	1965	2121	965	721	1830	591	1473	406	787	1118
5252	US (in)	136	20	37	55.25	124.25	107.75	55.5	41.25	101.5	27.75	79.75	30.5	53	42
	mm	3458	508	940	1403	3157	2735	1408	1045	2578	702	2026	778	1346	1063
5263	US (in)	136	20	37	55.25	124.25	107.75	61	47	112.5	27.5	49.75	30.5	64	42
	mm	3458	508	940	1403	3157	2735	1548	1194	2854	702	2026	778	1626	1063