

Image is a representation only, and may not show optional attachments.

SPECIFICATIONS

I-6, 4-Stroke-Cycle-Diesel

Emissions EPA Tier II and IMO Compliant
Displacement 12 L (732 cu. in.)
Rated Engine Speed 2300
Bore 130.0 mm (5.1 in.)
Stroke 150.0 mm (5.9 in.)
Aspiration Turbocharged-Aftercooled
Governor Electronic
Cooling System Heat Exchanger
Weight, Net Dry (approx) 1,174 kg (2,588 lb)
Refill Capacity	
Cooling System 45 L (12.0 U.S. gal)
Lube Oil System 28 L (7.5 U.S. gal)
Oil Change Interval 250 hrs
Caterpillar Diesel Engine Oil 10W30 or 15W40	
Center Sump Oil Pan	
Rotation (from flywheel end) Counterclockwise
Flywheel and Flywheel Housing SAE No. 1
Flywheel Teeth 113

STANDARD ENGINE EQUIPMENT

Air Inlet System

Corrosion resistant sea water aftercooler, air cleaner/fumes disposal (closed system), jacket water cooled turbocharger

Control System

Electronic governing, cold mode start strategy, power compensation for fuel temperature, programmable low idle, electronic diagnostics and fault logging, engine and transmission monitoring (speed, temperature, pressure), fuel/air ratio control

Cooling System

Thermostat and housing, gear-driven jacket water pump, self-priming, gear-driven sea water pump with rubber impeller, integral heat exchanger/expansion tank with removable tube bundle and replaceable copper-nickel tubes

Exhaust System

Watercooled exhaust manifold and turbocharger

Flywheels & Flywheel Housings

SAE No. 1 flywheel, 113 teeth, SAE No. 1 flywheel housing (10 degree slant pad), SAE standard rotation

Fuel System

Fuel filter, RH service on port, LH service on starboard, fuel transfer pump, fuel priming pump, flexible fuel lines

Instrumentation

Electric service meter

Lube System

Crankcase breather, oil cooler, spin-on oil filter, RH service on port, LH service on starboard, center sump oil pan, oil filler, dipstick, RH service on port, LH service on starboard, gear-driven oil pump

Mounting System

Front support

Power Take-Offs

Hydraulic pump drive, SAE A, 11 tooth spline, 57 ft-lbs max torque, counterclockwise as viewed from rear of the engine looking into the pump drive and turns 1.41 x engine speed, 345 mm crankshaft pulley, 15.88 mm width single groove

Protection System

12 or 24 volt electronic shutdown (energized-to-run)

General

Vibration damper, lifting eyes, RH or LH service options, literature, variable engine wiring, upper rear-facing customer wiring connector and ECAP connection, electronic installation kit (connectors, pins, sockets)

ISO Certification

Factory-designed systems built at Caterpillar ISO9001:2000 certified facilities

MARINE ENGINE PERFORMANCE

Preliminary

C12 DITA ACERT
492 bkW (660 bhp) @ 2300 rpm
E Rating (High Performance) — DM7530-01

EPA Tier II and IMO Compliant

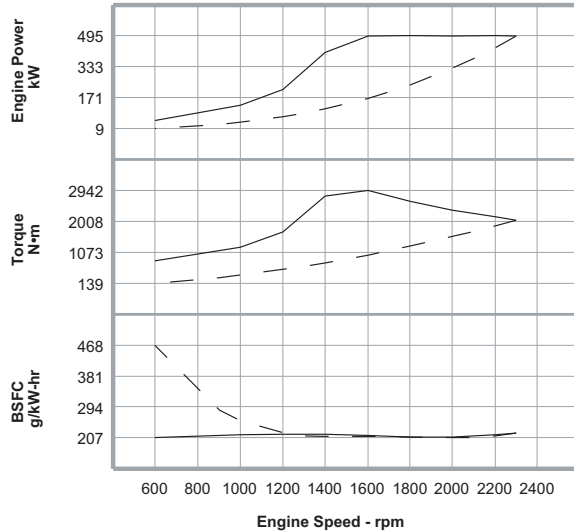

Metric **Maximum Power** **Prop Demand** **492 kW**

Preliminary Performance Data

	Engine Speed rpm	Engine Power kW	Engine Torque N·m	BSFC g/kW-hr	Fuel Rate L/hr
Maximum Power Data	2300	492.0	2043	220.0	129.0
	2200	494.9	2148	214.1	126.3
	2000	492.7	2353	208.0	122.2
	1800	493.8	2620	208.9	123.0
	1600	493.0	2942	212.6	124.9
	1400	406.3	2771	216.1	104.7
	1200	210.4	1675	216.3	54.3
	1000	128.2	1225	214.5	32.8
	600	50.9	810	206.9	12.5
	Prop Demand Data	2300	492.0	2043	220.0
2200		430.6	1869	211.2	108.4
2100		374.5	1703	207.0	92.4
2000		323.5	1545	206.6	79.7
1800		235.8	1251	209.1	58.8
1600		165.6	989	210.7	41.6
1400		111.0	757	210.1	27.8
1300		88.8	653	212.2	22.5
1200		69.9	556	220.8	18.4
900		29.5	313	283.8	10.0
600	8.7	139	468.5	4.9	

Cubic prop demand curve with 3.0 exponent for displacement hulls only.

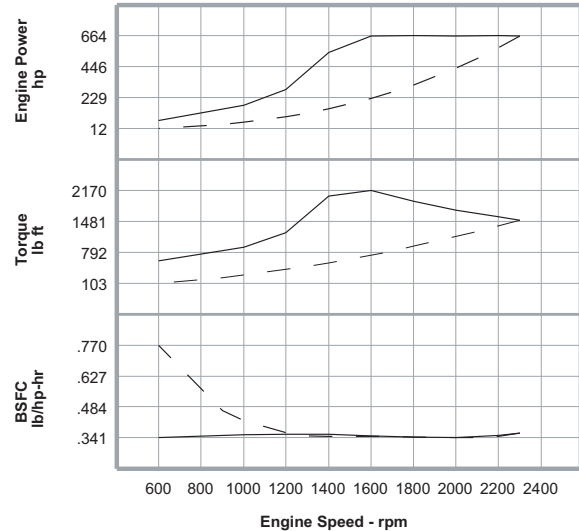

English **Maximum Power** **Prop Demand** **660 hp**

Preliminary Performance Data

	Engine Speed rpm	Engine Power hp	Engine Torque lb ft	BSFC lb/hp-hr	Fuel Rate gph
Maximum Power Data	2300	659.8	1507	.362	34.1
	2200	663.7	1584	.352	33.4
	2000	660.7	1735	.342	32.3
	1800	662.2	1932	.343	32.5
	1600	661.1	2170	.350	33.0
	1400	544.9	2044	.355	27.7
	1200	282.2	1235	.356	14.3
	1000	171.9	903	.353	8.7
	600	68.3	597	.340	3.3
	Prop Demand Data	2300	659.8	1507	.362
2200		577.4	1378	.347	28.6
2100		502.2	1256	.340	24.4
2000		433.8	1139	.340	21.1
1800		316.2	923	.344	15.5
1600		222.1	729	.346	11.0
1400		148.9	558	.345	7.3
1300		119.1	482	.349	5.9
1200		93.7	410	.363	4.9
900		39.6	231	.467	2.6
600	11.7	103	.770	1.3	

Power produced at the flywheel will be within standard tolerances up to 50°C (122°F) combustion air temperature measured at the air cleaner inlet, and fuel temperature up to 52°C (125°F) measured at the fuel filter base. Power rated in accordance with NMMA procedure as crankshaft power. Reduce crankshaft power by 3% for propeller shaft power.

DIMENSIONS

Preliminary

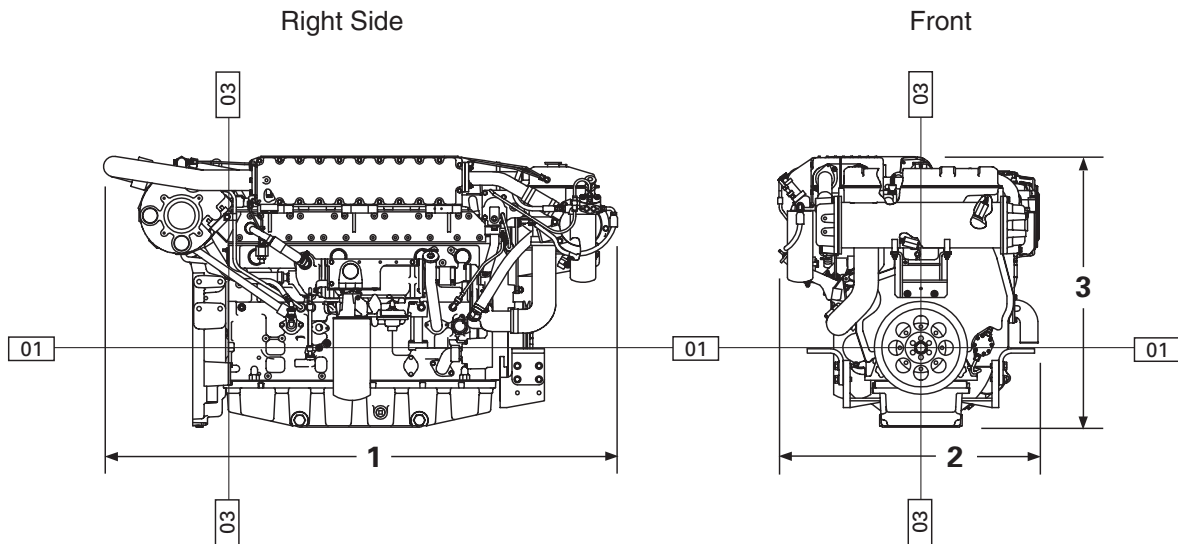

Preliminary Engine Dimensions		
(1) Length to Flywheel Housing	1573.9 mm	61.96 in
(2) Width	968.6 mm	38.13 in
(3) Height	1008.7 mm	39.71 in
Weight, Net Dry (approx)	1174 kg	2,588 lb

Note: Do not use for installation design.

RATING DEFINITIONS AND CONDITIONS

E Rating (High Performance)

% Load Factor: up to 30

% Time at Rated RPM: up to 8

Typical Time at Full Load: 1/2 hours out of 6

Typical Hour/Year: 250 to 1000

Typical Applications: For vessels operating at rated load and rated speed up to 8% of the time (up to 30% load factor). Typical applications could include but are not limited to vessels such as pleasure craft, harbor patrol boats, harbor master boats, some fishing or patrol boats. Typical operation ranges from 250 to 1000 hours per year.

Power at declared engine speed is in accordance with ISO3046-1:2002E. Caterpillar maintains ISO9001:1994/QS-9000 approved engine test facilities to assure accurate calibration of test equipment. Electronically controlled engines are set at the factory at the advertised power corrected to standard ambient conditions. The published fuel consumption rates are in accordance with ISO3046-1.

Fuel rates are based on fuel oil of 35° API [16°C (60°F)] gravity having an LHV of 42 780 kJ/kg (18,390 Btu/lb) when used at 29°C (85°F) and weighing 838.9 g/L (7.001 lb/U.S. gal). Additional ratings may be available for specific customer requirements. Consult your Caterpillar representative for additional information.

Performance data is calculated in accordance with tolerances and conditions stated in this specification sheet and is only intended for purposes of comparison with other manufacturers' engines. Actual engine performance may vary according to the particular application of the engine and operating conditions beyond Caterpillar's control.

Power produced at the flywheel will be within standard tolerances up to 50°C (122°F) combustion air temperature measured at the air cleaner inlet, and fuel temperature up to 52°C (125°F) measured at the fuel filter base. Power rated in accordance with NMMA procedure as crankshaft power. Reduce crankshaft power by 3% for propeller shaft power.

CAT, CATERPILLAR, ACERT, their respective logos and "Caterpillar Yellow," as well as corporate and product identity used herein, are trademarks of Caterpillar and may not be used without permission.

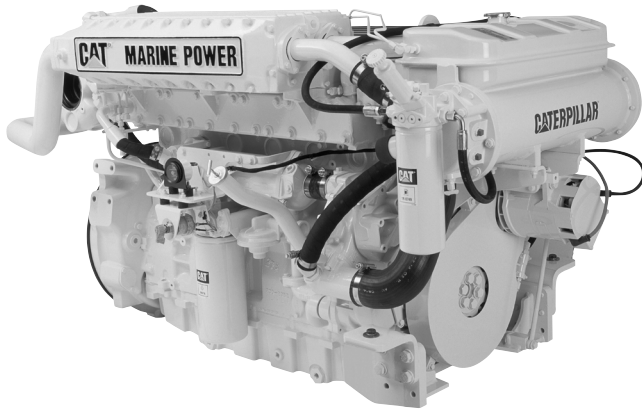

Image is a representation only, and may not show optional attachments.

SPECIFICATIONS

I-6, 4-Stroke-Cycle-Diesel

Emissions	EPA Tier II and IMO Compliant
Displacement	12 L (732.24 cu. in.)
Rated Engine Speed	2300
Bore	130 mm (5.1 in.)
Stroke	150 mm (5.9 in.)
Aspiration	Turbocharged-Aftercooled
Governor	Electronic
Cooling System	Heat Exchanger
Weight, Net Dry (approx)	1,174 kg (2,588 lb)
Refill Capacity	
Cooling System	45 L (12.0 U.S. gal)
Lube Oil System	28 L (7.5 U.S. gal)
Oil Change Interval	250 hrs
	Caterpillar Diesel Engine Oil 10W30 or 15W40
	Center Sump Oil Pan
Rotation (from flywheel end)	Counterclockwise
Flywheel and Flywheel Housing	SAE No. 1
Flywheel Teeth	113

STANDARD ENGINE EQUIPMENT

Air Inlet System

Corrosion resistant sea water aftercooler, air cleaner/fumes disposal (closed system), jacket water cooled turbocharger

Control System

Electronic governing, cold mode start strategy, power compensation for fuel temperature, programmable low idle, electronic diagnostics and fault logging, engine and transmission monitoring (speed, temperature, pressure), fuel/air ratio control

Cooling System

Thermostat and housing, gear-driven jacket water pump, self-priming, gear-driven sea water pump with rubber impeller, integral heat exchanger/expansion tank with removable tube bundle and replaceable copper-nickel tubes

Exhaust System

Watercooled exhaust manifold and turbocharger

Flywheels & Flywheel Housings

SAE No. 1 flywheel, 113 teeth, SAE No. 1 flywheel housing (10 degree slant pad), SAE standard rotation

Fuel System

Fuel filter, RH service on port, LH service on starboard, fuel transfer pump, fuel priming pump, flexible fuel lines

Instrumentation

Electric service meter

Lube System

Crankcase breather, oil cooler, spin-on oil filter, RH service on port, LH service on starboard, center sump oil pan, oil filler, dipstick, RH service on port, LH service on starboard, gear-driven oil pump

Mounting System

Front support

Power Take-Offs

Hydraulic pump drive, SAE A, 11 tooth spline, 57 ft-lbs max torque, counterclockwise as viewed from rear of the engine looking into the pump drive and turns 1.41 x engine speed, 345 mm crankshaft pulley, 15.88 mm width single groove

Protection System

12 or 24 volt electronic shutdown (energized-to-run)

General

Vibration damper, lifting eyes, RH or LH service options, literature, variable engine wiring, upper rear-facing customer wiring connector and ECAP connection, electronic installation kit (connectors, pins, sockets)

ISO Certification

Factory-designed systems built at Caterpillar ISO9001:2000 certified facilities

MARINE ENGINE PERFORMANCE

Preliminary

C12 DITA ACERT
526 kW (705 hp) @ 2300 rpm
E Rating (High Performance) — DM7676-00

EPA Tier II and IMO Compliant

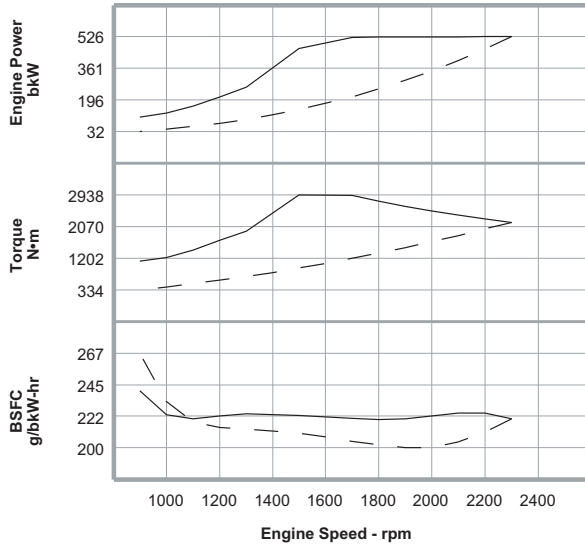

Metric Maximum Power Prop Demand 526 bkW

Preliminary Performance Data

	Engine Speed rpm	Engine Power bkW	Engine Torque N·m	BSFC g/bkW-hr	Fuel Rate L/hr
Maximum Power Data	2300	526.0	2184	220.2	138.1
	2200	525.0	2279	224.9	140.7
	2100	523.1	2378	224.5	140.0
	2000	522.0	2493	222.3	138.3
	1900	522.0	2624	220.4	137.1
	1700	521.1	2927	220.8	137.1
	1500	461.5	2938	222.7	122.5
	1300	263.8	1938	223.9	70.4
	1200	211.4	1683	222.2	56.0
	1000	128.3	1225	223.3	34.1
900	105.5	1120	240.5	30.3	
Prop Demand Data	2300	526.0	2184	220.2	138.1
	2200	460.3	1998	210.9	115.7
	2100	400.4	1821	204.0	97.4
	1900	296.5	1490	200.0	70.7
	1800	252.1	1338	202.0	60.7
	1600	177.1	1057	207.7	43.8
	1500	145.9	929	210.4	36.6
	1300	95.0	698	213.0	24.1
	1200	74.7	594	214.2	19.1
	1000	43.2	413	232.9	12.0
900	31.5	334	266.8	10.0	

Cubic prop demand curve with 3.0 exponent for displacement hulls only.

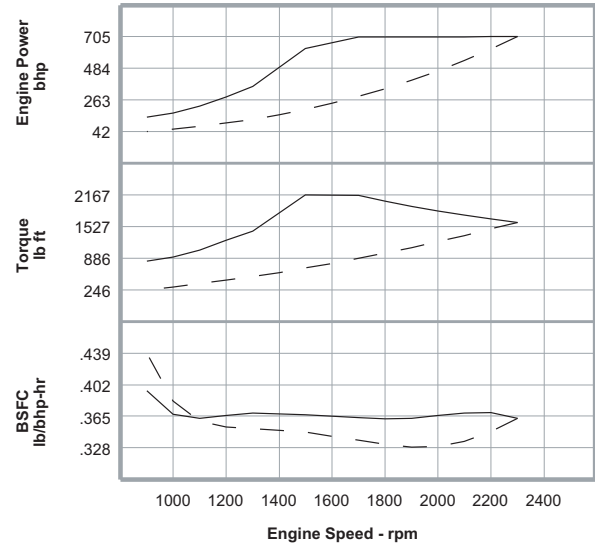

English Maximum Power Prop Demand 705 bhp

Preliminary Performance Data

	Engine Speed rpm	Engine Power bhp	Engine Torque lb ft	BSFC lb/bhp-hr	Fuel Rate gph
Maximum Power Data	2300	705.4	1611	.362	36.5
	2200	704.0	1681	.370	37.2
	2100	701.5	1754	.369	37.0
	2000	700.0	1839	.365	36.5
	1900	700.0	1935	.362	36.2
	1700	698.8	2159	.363	36.2
	1500	618.9	2167	.366	32.4
	1300	353.8	1429	.368	18.6
	1200	283.5	1241	.365	14.8
	1000	172.1	903	.367	9.0
900	141.5	826	.395	8.0	
Prop Demand Data	2300	705.4	1611	.362	36.5
	2200	617.3	1474	.347	30.6
	2100	536.9	1343	.335	25.7
	1900	397.6	1099	.329	18.7
	1800	338.1	987	.332	16.0
	1600	237.5	780	.341	11.6
	1500	195.7	685	.346	9.7
	1300	127.4	515	.350	6.4
	1200	100.2	438	.352	5.0
	1000	57.9	305	.383	3.2
900	42.2	246	.439	2.6	

Power produced at the flywheel will be within standard tolerances up to 50°C (122°F) combustion air temperature measured at the air cleaner inlet, and fuel temperature up to 52°C (125°F) measured at the fuel filter base. Power rated in accordance with NMMA procedure as crankshaft power. Reduce crankshaft power by 3% for propeller shaft power.

DIMENSIONS

Preliminary

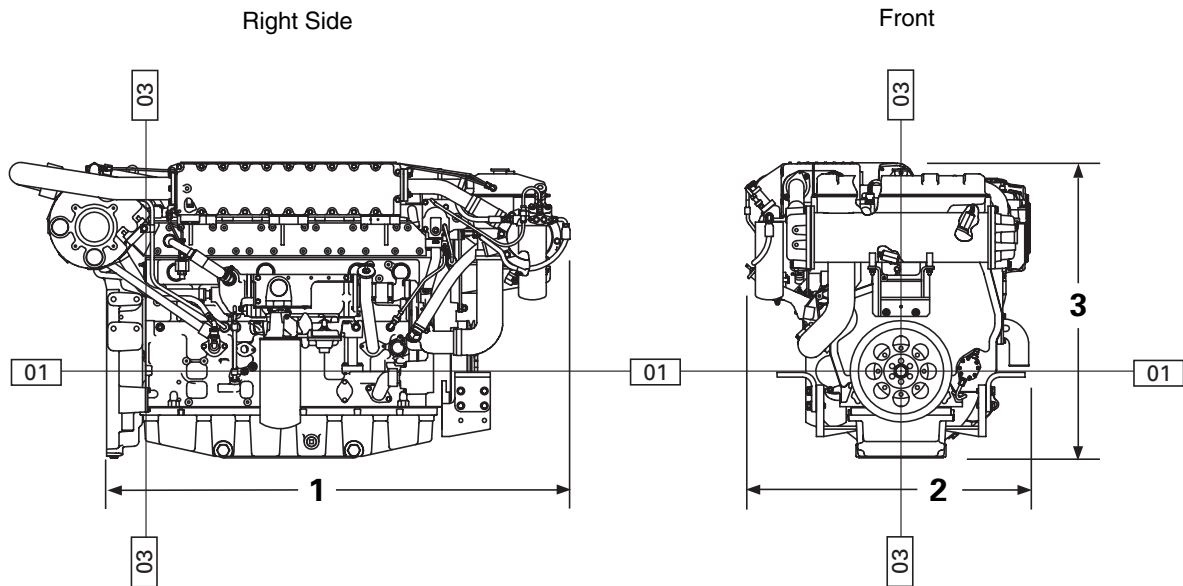

Preliminary Engine Dimensions		
(1) Length to Flywheel Housing	1573.9 mm	61.96 in
(2) Width	968.6 mm	38.13 in
(3) Height	1008.7 mm	39.71 in
Weight, Net Dry (approx)	1174 kg	2,588 lb

Note: Do not use for installation design.

RATING DEFINITIONS AND CONDITIONS

E Rating (High Performance)

% Load Factor: up to 30

% Time at Rated RPM: up to 8

Typical Time at Full Load: 1/2 hours out of 6

Typical Hour/Year: 250 to 1000

Typical Applications: For vessels operating at rated load and rated speed up to 8% of the time (up to 30% load factor). Typical applications could include but are not limited to vessels such as pleasure craft, harbor patrol boats, harbor master boats, some fishing or patrol boats. Typical operation ranges from 250 to 1000 hours per year.

Power at declared engine speed is in accordance with ISO3046-1:2002E. Caterpillar maintains ISO9001:1994/QS-9000 approved engine test facilities to assure accurate calibration of test equipment. Electronically controlled engines are set at the factory at the advertised power corrected to standard ambient conditions. The published fuel consumption rates are in accordance with ISO3046-1.

Fuel rates are based on fuel oil of 35° API [16°C (60°F)] gravity having an LHV of 42 780 kJ/kg (18,390 Btu/lb) when used at 29°C (85°F) and weighing 838.9 g/L (7.001 lb/U.S. gal). Additional ratings may be available for specific customer requirements. Consult your Caterpillar representative for additional information.

Performance data is calculated in accordance with tolerances and conditions stated in this specification sheet and is only intended for purposes of comparison with other manufacturers' engines. Actual engine performance may vary according to the particular application of the engine and operating conditions beyond Caterpillar's control.

Power produced at the flywheel will be within standard tolerances up to 50°C (122°F) combustion air temperature measured at the air cleaner inlet, and fuel temperature up to 52°C (125°F) measured at the fuel filter base. Power rated in accordance with NMMA procedure as crankshaft power. Reduce crankshaft power by 3% for propeller shaft power.

CAT, CATERPILLAR, ACERT, their respective logos and "Caterpillar Yellow," as well as corporate and product identity used herein, are trademarks of Caterpillar and may not be used without permission.