

## SPECIFICATIONS

### 516AT Trommel

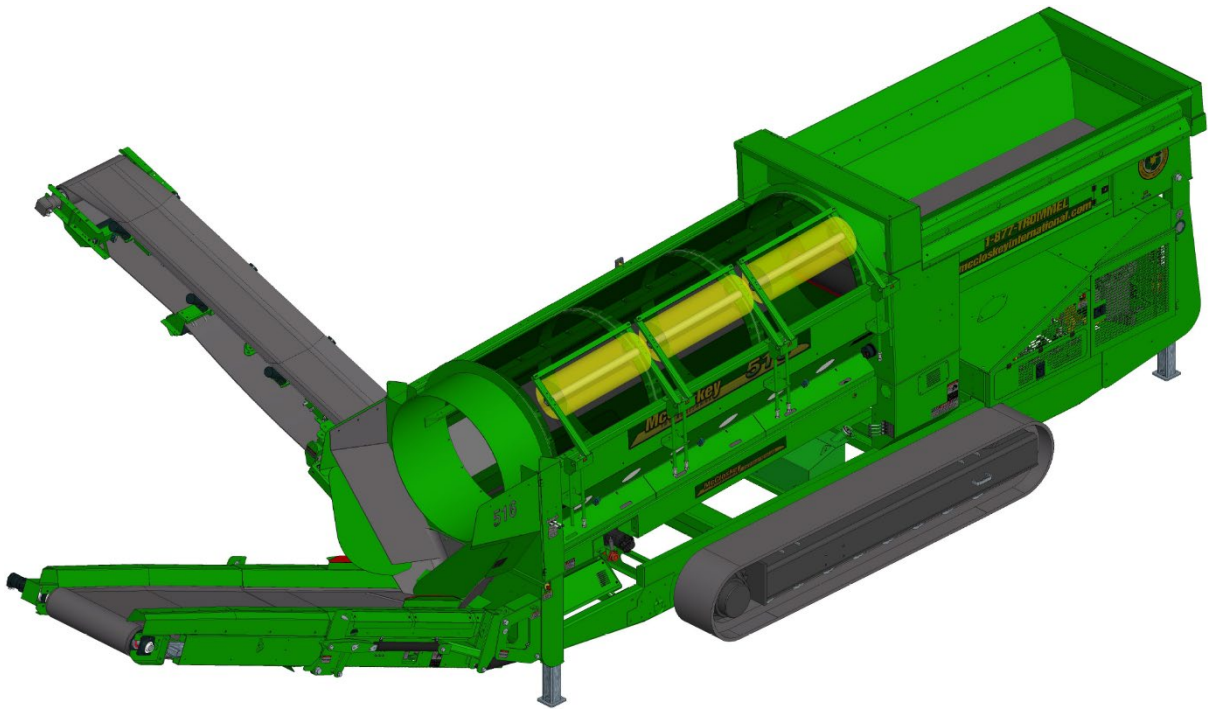

Note: Optional equipment may be displayed

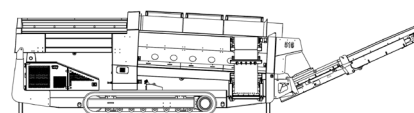

## DESCRIPTION

Heavy duty mobile trommel with following features:

- 5' x 16' heavy duty trommel drum
- 74 kW (100 hp) diesel engine
- Track mobility
- Integrated hydraulic folding stockpiling conveyors
- Fast on-site setup time (10 minutes)

## SAFETY FEATURES

- External belt alignment points
- External grease points
- Full safety guarding for nip points

## DIMENSIONS AND WEIGHTS

### Working Dimensions

Length.....	14.11 m (46' – 3½")
Width .....	7.20 m (23' – 7½")
Height .....	3.52 m (11' – 6½")

### Transport Dimensions

Length.....	10.64 m (34' – 11")
Width .....	2.83 m (9' – 3½")
Transport Height.....	3.56 m (11' – 8")
Loading Height .....	2.95 m (9' – 8")

Weight (approximate).....	21 250 kg (46 800 lbs)
---------------------------	------------------------

## CAPACITIES

Hydraulic tank capacity .....	680 L (180 US gal)
Diesel tank capacity.....	295 L (78 US gal)
Hopper Capacity.....	4.97 m <sup>3</sup> (6.5 yd <sup>3</sup> )

## FEED CONVEYOR

Belt width .....	900 mm (36")
Belt spec.....	Plain 500/3 5+1.5
Drive drum diameter.....	324 mm (12 ¾")
Tail drum diameter.....	305 mm (12")
Gearbox.....	Brevini CTD2051
Gearbox ratio.....	34,7:1
Gearbox torque.....	5,500 Nm cont
Motor .....	Sam Hydraulik BRZ250
Flow rate.....	68 lpm (18 US gpm)
Adjustable speed .....	Yes
Maximum speed .....	10 rpm

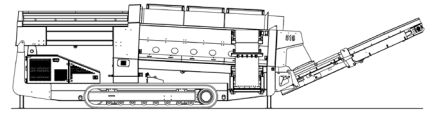

**FINES CONVEYOR**

Belt width .....	1200 mm (48")
Belt spec .....	Plain 400/2 4+2
Drive drum diameter .....	203 mm (8")
Tail drum diameter .....	203 mm (8")
Motor .....	OMV 630
Flow rate .....	83 lpm (22 US gpm)
Maximum speed .....	132 rpm

**SIDE CONVEYOR**

Stockpile height .....	2.53 m (8' – 3½")
Belt width .....	800 mm (32")
Belt spec .....	Plain - 400/2 4+2
Drive drum diameter .....	203 mm (8")
Tail drum diameter .....	254 mm (10")
Motor .....	OMT 500
Flow rate .....	83 lpm (22 US gpm)
Maximum speed .....	167 rpm

**OVERSIZE CONVEYOR**

Stockpile height .....	2.69 m (8' – 10")
Belt width .....	1050 mm (42")
Drive drum diameter .....	254 mm (10")
Tail drum diameter .....	254 mm (10")
Motor .....	White RE32
Flow rate .....	68 lpm (18 US gpm)
Maximum speed .....	127 rpm
Adjustable speed .....	Yes

**TROMMEL (DRUM)**

Dimensions .....	1.52 m x 4.88 m (5' x 16')
Screening Area .....	17.65 m <sup>2</sup> (190 ft <sup>2</sup> )
Trommel angle .....	5 deg
Trommel motor .....	White DT19 (19.3 cc/rev)
Drive system .....	Direct drive with 18x7 rubber wheels
Hydraulic flow rate .....	125 lpm (33 US gpm)
Trommel speed .....	10 – 30 rpm
Adjustable speed .....	Yes
Longitudinal Trommel Supports .....	4 angle type lifters
Cleaning Brushes .....	Ground adjustable Ø16x 50" polyester brushes

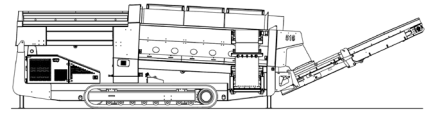

**POWERUNIT AND HYDRAULICS**

Engine power.....	74 kW (100) hp diesel engine
Engine speed.....	2200 rpm
Flywheel pump 1 .....	P257 64, 42, 42
LH PTO pump 2.....	P124 34, 10
Total system flow.....	360 lpm (95 US gpm)
Hydraulic tank ratio.....	1.9 : 1
Hydraulic oil cooler .....	Yes

**ELECTRICS**

Emergency stops.....	4 off, 2 powerunit, 2 chassis RH&LH
Chassis cabling .....	Armored cable
Start Siren.....	Yes – 10 sec delay
Engine room light.....	Yes
Radio-controlled tracks.....	Yes
Pendant track control .....	Yes, plugged at powerunit
Engine shutdowns:	
▪ Low oil pressure	
▪ High water temperature	
▪ Air filter blockage (selectable)	
▪ Fuel contamination	
▪ Low hydraulic tank level	

**TRACKS**

Width .....	500 mm (19.7")
Length.....	4590 mm (15'-1")
Height .....	795 mm (31.3")
Gearbox.....	Bonfiglioli 707
Ratio .....	122:1
Motor .....	Rexroth 63
Motor speed (max) .....	1.5 km/h (0.9 mph)
Motor flow rate.....	83 lpm (22 US gpm)
Ground contact pressure.....	117 kPa (17 psi)
Attachment to chassis .....	Bolt-on for quick change

**OPTIONS**

- Hydraulic Tipping Grid
- Double Brushes
- Auto Reversing Fan
- Auxiliary Hydraulic Circuit
- Punch Plate Screens
- Remote Feeder on/off
- Spare Drum

