



**3516C – SS
MARINE
PROPULSION**

1673, 1775, 1876 mhp
(1650, 1750, 1850 bhp)
1230, 1305, 1379 kW

SPECIFICATIONS

V-16, 4-Stroke-Cycle-Diesel

Emissions EPA Tier 2 compliant*, IMO compliant
EU Stage 3A Inland Waterway
accepted as equivalent CCNR Stage II
Displacement 69 L (4211 cu. in.)
Rated Engine Speed 1200
Bore 170.0 mm (6.7 in.)
Stroke 190.0 mm (7.48 in.)
Aspiration Turbocharged-Aftercooled
Governor ADEM™ A3
Cooling System Heat Exchanger
Weight, Net Dry
(approx) 7961-8629 kg (17,550-19,025 lb)
Refill Capacity
Cooling System (approx) 233 L (61.6 gal)
Lube Oil System 810.1 L (214 gal)
Oil Change Interval 1000 hr
Caterpillar Diesel Engine Oil 10W30 or 15W40
Deep Sump Oil Pan
Rotation (from flywheel end) Counterclockwise
Flywheel and Flywheel Housing SAE No. 00
Flywheel Teeth 183
3516C Propulsion 516DM52 (standard)
516DM53 (reverse)

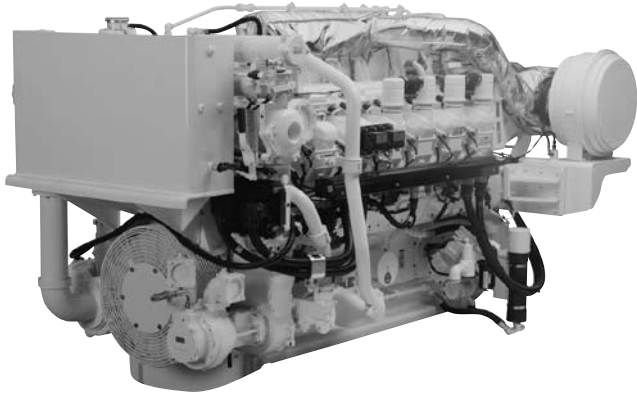

Image shown may not reflect actual engine

A rating

1673 mhp (1650 bhp) 1230 kW @ 1200 rpm (DM8473)

B rating

1775 mhp (1750 bhp) 1305 kW @ 1200 rpm (DM8474)

C rating

1876 mhp (1850 bhp) 1379 kW @ 1200 rpm (DM8475)

*EPA Tier 2 certification in process at time of print

STANDARD ENGINE EQUIPMENT

Air Inlet System

Corrosion resistant separate circuit freshwater aftercooled, powercore air cleaner

Control System

Dual Caterpillar® A3 Electronic Control Unit (ECU) LH with electronic unit injector fuel system rigid wiring harness (10 amp DC power required to drive ECU)

Cooling System

Gear-driven centrifugal auxiliary sea water pump, gear-driven centrifugal jacket water pump, expansion tank for commercial engines, coolant shunt tank on lightweight engines, engine oil cooler, thermostats and housing.

ECU Functions

Programmable low idle, SAEJ1939 data link, Cat® data link, engine diagnostics, general alarm relay, programmable parameters (system application and tattletales), Caterpillar ET service tool interface, remote shutdown, shutdown notify, load feedback, overspeed shutdown, overspeed verify

Exhaust System

Dry gas-tight exhaust manifolds with heat shields, dual turbochargers with watercooled bearings and heat shield. Wastegate on select ratings.

Fuel System

Electronically controlled unit injectors, simplex fuel filter (RH) with service indicators, fuel transfer pump

Instrumentation

Marine Power Display of: Engine oil pressure, engine water temperature, fuel pressure, engine speed, fuel consumption, overspeed shutdown notification light, prelube and shutdown override

Lube System

Gear-driven pump, top-mounted dual crankcase breather groups, simplex oil filter, oil filler and dipstick.

Power Take-Offs

Accessory drive, two-sided front housing

Protection System

Emergency stop pushbutton, safety shutoff, oil pressure, and water temperature

General

Two lifting eyes mounted to cylinder heads, Caterpillar yellow paint, parts books and maintenance manuals, shrink-wrap.

ISO Certification

Factory-designed systems built at Caterpillar ISO 9001:2000 certified facilities.

MARINE ENGINE PERFORMANCE

3516C DITA

1673 mhp (1650 bhp) 1230 bkW @ 1200 rpm
A Rating — DM8473-01

Aftercooler Temperature 48°C (118°F)

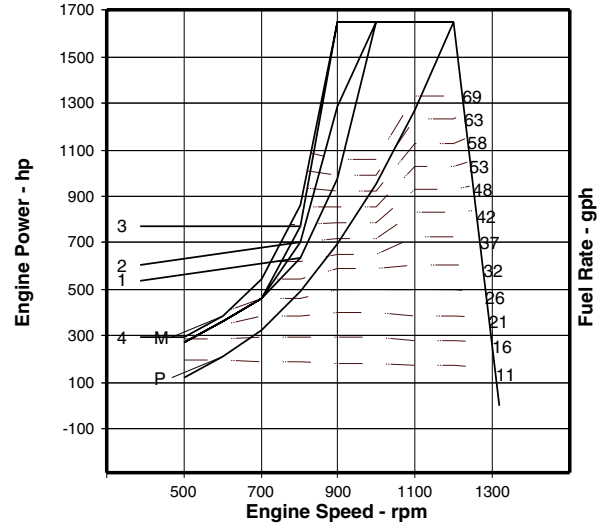
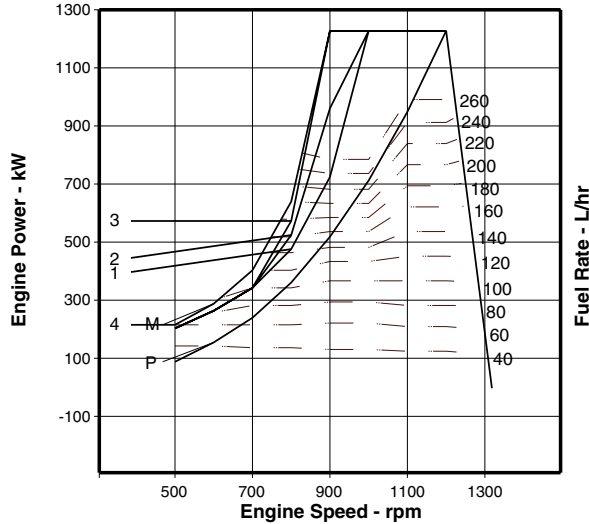

Performance Data

Performance Data

	Engine Speed rpm	Engine Power kW	BSFC g/kW-hr	Fuel Rate L/hr	Boost Press kPa Gauge	Intake Air Flow m³/min	Exh Manif Temp °C	Exh Gas Flow m³/min
Zone Limit	1200	1231	204	298.6	242.4	120.3	532	258.3
Curve: 1	1000	1231	198	290.2	228.2	95.8	597	232.3
	900	728	209	181.6	103.1	54.0	625	142.4
	800	476	221	125.4	47.2	33.9	625	92.2
	600	269	234	74.8	14.3	19.8	555	49.5
	500	204	232	56.3	8.0	15.6	508	36.3
Zone Limit	1200	1231	204	298.6	0.0	120.3	532	258.3
Curve: 2	1000	1231	198	290.2	0.0	95.8	597	232.3
	900	962	203	232.5	0.0	66.5	650	177.8
	800	524	219	136.4	0.0	35.6	650	98.6
	600	269	234	74.8	0.0	19.8	555	49.5
	500	204	232	56.3	0.0	15.6	508	36.3
Zone Limit	1200	1231	204	298.6	242.4	120.3	532	258.3
Curve: 3	1000	1231	198	290.2	228.2	95.8	597	232.3
	900	1231	199	291.8	215.1	83.9	664	221.2
	800	577	217	149.2	61.8	37.5	675	106.1
	600	269	234	74.8	14.3	19.8	555	49.5
	500	204	232	56.3	8.0	15.6	508	36.3
Zone Limit	1200	1231	204	298.6	242.4	120.3	532	258.3
Curve: 4	1000	1231	198	290.2	228.2	95.8	597	232.3
	900	1231	199	291.8	215.1	83.9	664	221.2
	800	641	216	165.3	73.0	39.8	700	116.0
	600	288	236	80.9	16.0	20.0	594	51.8
	500	218	237	61.5	9.0	15.8	546	38.1
Max Power Curve: M	1200	1231	204	298.6	242.4	120.3	532	258.3
	1000	1231	198	290.2	228.2	95.8	597	232.3
	900	1231	199	291.8	215.1	83.9	664	221.2
	800	641	216	165.3	73.0	39.8	700	116.0
	600	288	236	80.9	16.0	20.0	594	51.8
	500	218	237	61.5	9.0	15.8	546	38.1
Prop Demand Curve: P	1200	1231	204	298.6	242.4	120.3	532	258.3
	1000	712	212	179.6	114.3	61.9	560	151.0
	900	519	219	135.5	64.2	43.6	570	110.7
	800	365	228	99.0	33.4	31.0	548	77.8
	600	154	235	43.2	6.8	18.8	347	36.1
	500	89	260	27.5	2.8	15.0	269	26.3

	Engine Speed rpm	Engine Power hp	BSFC lb/hp-hr	Fuel Rate gph	Boost Press in-hg Gauge	Intake Air Flow cfm	Exh Manif Temp °F	Exh Gas Flow cfm
Zone Limit	1200	1651	.335	78.9	71.8	4248	990	9122
Curve: 1	1000	1651	.326	76.7	67.6	3383	1107	8204
	900	976	.344	48.0	30.5	1907	1157	5029
	800	638	.363	33.1	14.0	1197	1157	3256
	600	361	.385	19.8	4.2	699	1031	1748
	500	274	.381	14.9	2.4	551	946	1282
Zone Limit	1200	1651	.335	78.9	0.0	4248	990	9122
Curve: 2	1000	1651	.326	76.7	0.0	3383	1107	8204
	900	1290	.334	61.4	0.0	2348	1202	6279
	800	703	.360	36.0	0.0	1257	1202	3482
	600	361	.385	19.8	0.0	699	1031	1748
	500	274	.381	14.9	0.0	551	946	1282
Zone Limit	1200	1651	.335	78.9	71.8	4248	990	9122
Curve: 3	1000	1651	.326	76.7	67.6	3383	1107	8204
	900	1651	.327	77.1	63.7	2963	1227	7812
	800	774	.357	39.4	18.3	1324	1247	3747
	600	361	.385	19.8	4.2	699	1031	1748
	500	274	.381	14.9	2.4	551	946	1282
Zone Limit	1200	1651	.335	78.9	71.8	4248	990	9122
Curve: 4	1000	1651	.326	76.7	67.6	3383	1107	8204
	900	1651	.327	77.1	63.7	2963	1227	7812
	800	860	.355	43.7	21.6	1406	1292	4097
	600	386	.388	21.4	4.7	706	1101	1829
	500	292	.390	16.2	2.7	558	1015	1345
Max Power Curve: M	1200	1651	.335	78.9	71.8	4248	990	9122
	1000	1651	.326	76.7	67.6	3383	1107	8204
	900	1651	.327	77.1	63.7	2963	1227	7812
	800	860	.355	43.7	21.6	1406	1292	4097
	600	386	.388	21.4	4.7	706	1101	1829
	500	292	.390	16.2	2.7	558	1015	1345
Prop Demand Curve: P	1200	1651	.335	78.9	71.8	4248	990	9122
	1000	955	.349	47.4	33.8	2186	1040	5333
	900	696	.360	35.8	19.0	1540	1058	3909
	800	489	.375	26.2	9.9	1095	1018	2747
	600	207	.386	11.4	2.0	664	657	1275
	500	119	.427	7.3	0.8	530	516	929

Brake Mean Effective Pressure 1783 kPa
Heat Rejection to Coolant (total) 480 kW
Heat Rejection to Aftercooler 349 kW
Heat Rejection to Exhaust (total) 996 kW
Heat Rejection to Atmosphere from Engine 116 kW

Brake Mean Effective Pressure 259 psi
Heat Rejection to Coolant (total) 27298 btu/min
Heat Rejection to Aftercooler 19848 btu/min
Heat Rejection to Exhaust (total) 56642 btu/min
Heat Rejection to Atmosphere from Engine 6597 btu/min

MARINE ENGINE PERFORMANCE

3516C DITA

1775 mhp (1750 bhp) 1305 bkW @ 1200 rpm
B Rating — DM8474-01

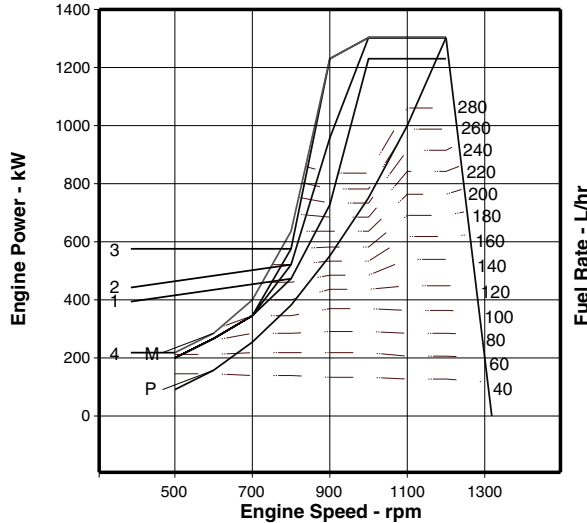

Performance Data

	Engine Speed rpm	Engine Power kW	BSFC g/kW-hr	Fuel Rate L/hr	Boost Press kPa Gauge	Intake Air Flow m³/min	Exh Manif Temp °C	Exh Gas Flow m³/min
Zone Limit	1200	1231	204	298.6	242.4	120.3	532	258.3
Curve: 1	1000	1231	198	290.2	228.2	95.8	597	232.3
	900	728	209	181.6	103.1	54.0	625	142.4
	800	476	221	125.4	47.2	33.9	625	92.2
	600	269	234	74.8	14.3	19.8	555	49.5
	500	204	232	56.3	8.0	15.6	508	36.3
Zone Limit	1200	1305	205	318.8	0.0	123.4	551	272.7
Curve: 2	1000	1305	198	307.5	0.0	100.9	603	245.4
	900	962	203	232.5	0.0	66.5	650	177.8
	800	524	219	136.4	0.0	35.6	650	98.6
	600	269	234	74.8	0.0	19.8	555	49.5
	500	204	232	56.3	0.0	15.6	508	36.3
Zone Limit	1200	1305	205	318.8	254.8	123.4	551	272.7
Curve: 3	1000	1305	198	307.5	245.0	100.9	603	245.4
	900	1231	199	291.8	215.1	83.9	664	221.2
	800	577	217	149.2	61.8	37.5	675	106.1
	600	269	234	74.8	14.3	19.8	555	49.5
	500	204	232	56.3	8.0	15.6	508	36.3
Zone Limit	1200	1305	205	318.8	254.8	123.4	551	272.7
Curve: 4	1000	1305	198	307.5	245.0	100.9	603	245.4
	900	1231	199	291.8	215.1	83.9	664	221.2
	800	641	216	165.3	73.0	39.8	700	116.0
	600	288	236	80.9	16.0	20.0	594	51.8
	500	218	237	61.5	9.0	15.8	546	38.1
Max Power	1200	1305	205	318.8	254.8	123.4	551	272.7
Curve: M	1000	1305	198	307.5	245.0	100.9	603	245.4
	900	1231	199	291.8	215.1	83.9	664	221.2
	800	641	216	165.3	73.0	39.8	700	116.0
	600	288	236	80.9	16.0	20.0	594	51.8
	500	218	237	61.5	9.0	15.8	546	38.1
Prop Demand	1200	1305	205	318.8	254.8	123.4	551	272.7
Curve: P	1000	755	210	189.2	124.5	65.2	564	158.5
	900	551	217	142.5	69.9	45.1	583	115.3
	800	387	226	104.3	36.0	31.5	565	80.6
	600	163	234	45.4	7.2	18.8	361	37.1
	500	94	256	28.8	3.0	15.0	280	26.9

Brake Mean Effective Pressure 1891 kPa
Heat Rejection to Coolant (total) 501 kW
Heat Rejection to Aftercooler 382 kW
Heat Rejection to Exhaust (total) 1076 kW
Heat Rejection to Atmosphere from Engine 121 kW

Aftercooler Temperature 48°C (118°F)

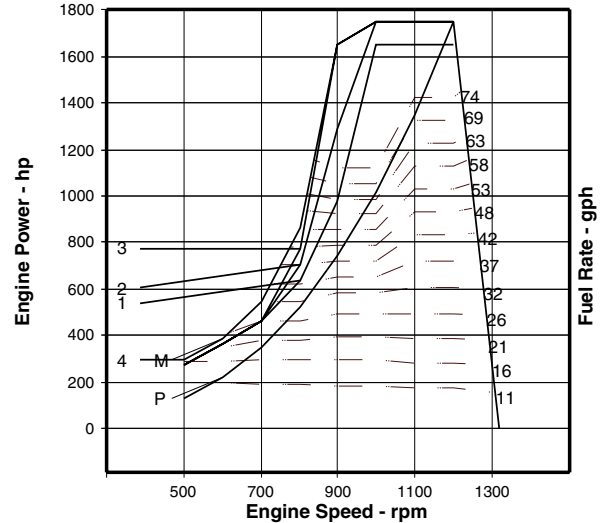

Performance Data

	Engine Speed rpm	Engine Power hp	BSFC lb/hp-hr	Fuel Rate gph	Boost Press in-hg Gauge	Intake Air Flow cfm	Exh Manif Temp °F	Exh Gas Flow cfm
Zone Limit	1200	1651	.335	78.9	71.8	4248	990	9122
Curve: 1	1000	1651	.326	76.7	67.6	3383	1107	8204
	900	976	.344	48.0	30.5	1907	1157	5029
	800	638	.363	33.1	14.0	1197	1157	3256
	600	361	.385	19.8	4.2	699	1031	1748
	500	274	.381	14.9	2.4	551	946	1282
Zone Limit	1200	1750	.337	84.2	0.0	4358	1024	9630
Curve: 2	1000	1750	.326	81.2	0.0	3563	1117	8666
	900	1290	.334	61.4	0.0	2348	1202	6279
	800	703	.360	36.0	0.0	1257	1202	3482
	600	361	.385	19.8	0.0	699	1031	1748
	500	274	.381	14.9	0.0	551	946	1282
Zone Limit	1200	1750	.337	84.2	75.5	4358	1024	9630
Curve: 3	1000	1750	.326	81.2	72.6	3563	1117	8666
	900	1651	.327	77.1	63.7	2963	1227	7812
	800	774	.357	39.4	18.3	1324	1247	3747
	600	361	.385	19.8	4.2	699	1031	1748
	500	274	.381	14.9	2.4	551	946	1282
Zone Limit	1200	1750	.337	84.2	75.5	4358	1024	9630
Curve: 4	1000	1750	.326	81.2	72.6	3563	1117	8666
	900	1651	.327	77.1	63.7	2963	1227	7812
	800	860	.355	43.7	21.6	1406	1292	4097
	600	386	.388	21.4	4.7	706	1101	1829
	500	292	.390	16.2	2.7	558	1015	1345
Max Power	1200	1750	.337	84.2	75.5	4358	1024	9630
Curve: M	1000	1750	.326	81.2	72.6	3563	1117	8666
	900	1651	.327	77.1	63.7	2963	1227	7812
	800	860	.355	43.7	21.6	1406	1292	4097
	600	386	.388	21.4	4.7	706	1101	1829
	500	292	.390	16.2	2.7	558	1015	1345
Prop Demand	1200	1750	.337	84.2	75.5	4358	1024	9630
Curve: P	1000	1012	.345	50.0	36.9	2303	1047	5597
	900	739	.357	37.6	20.7	1593	1081	4072
	800	519	.372	27.6	10.7	1112	1049	2846
	600	219	.385	12.0	2.1	664	682	1310
	500	126	.421	7.6	0.9	530	536	950

Brake Mean Effective Pressure 274 psi
Heat Rejection to Coolant (total) 28492 btu/min
Heat Rejection to Aftercooler 21724 btu/min
Heat Rejection to Exhaust (total) 61192 btu/min
Heat Rejection to Atmosphere from Engine 6881 btu/min

MARINE ENGINE PERFORMANCE

3516C DITA
1876 mhp (1850 bhp) 1379 kW @ 1200 rpm
C Rating — DM8475-01

Aftercooler Temperature 48°C (118°F)

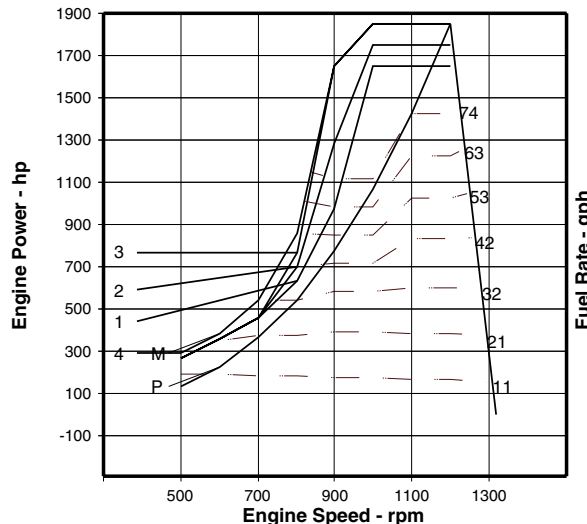
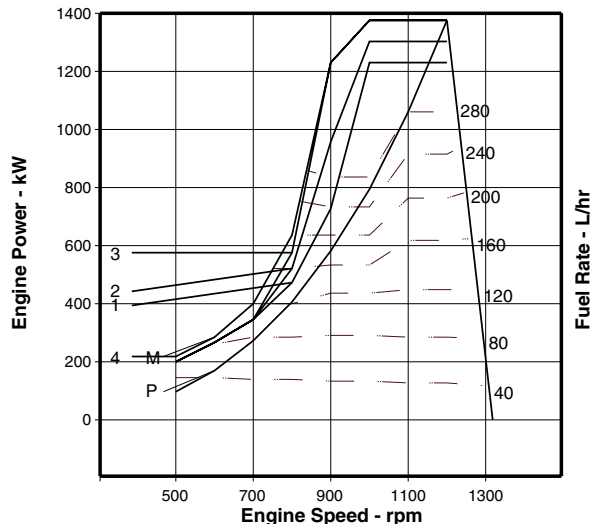

Performance Data

Performance Data

	Engine Speed rpm	Engine Power kW	BSFC g/kW-hr	Fuel Rate L/hr	Boost Press kPa Gauge	Intake Air Flow m³/min	Exh Manif Temp °C	Exh Gas Flow m³/min
Zone Limit Curve: 1	1200	1231	204	298.6	242.4	120.3	532	258.3
	1000	1231	198	290.2	228.2	95.8	597	232.3
	900	728	209	181.6	103.1	54.0	625	142.4
	800	476	221	125.4	47.2	33.9	625	92.2
	600	269	234	74.8	14.3	19.8	555	49.5
	500	204	232	56.3	8.0	15.6	508	36.3
Zone Limit Curve: 2	1200	1305	205	318.8	0.0	123.4	551	272.7
	1000	1305	198	307.5	0.0	100.9	603	245.4
	900	962	203	232.5	0.0	66.5	650	177.8
	800	524	219	136.4	0.0	35.6	650	98.6
	600	269	234	74.8	0.0	19.8	555	49.5
	500	204	232	56.3	0.0	15.6	508	36.3
Zone Limit Curve: 3	1200	1380	207	340.5	266.4	126.2	575	288.1
	1000	1380	198	325.6	261.7	106.1	609	259.1
	900	1231	199	291.8	215.1	83.9	664	221.2
	800	577	217	149.2	61.8	37.5	675	106.1
	600	269	234	74.8	14.3	19.8	555	49.5
	500	204	232	56.3	8.0	15.6	508	36.3
Zone Limit Curve: 4	1200	1380	207	340.5	266.4	126.2	575	288.1
	1000	1380	198	325.6	261.7	106.1	609	259.1
	900	1231	199	291.8	215.1	83.9	664	221.2
	800	641	216	165.3	73.0	39.8	700	116.0
	600	288	236	80.9	16.0	20.0	594	51.8
	500	218	237	61.5	9.0	15.8	546	38.1
Max Power Curve: M	1200	1380	207	340.5	266.4	126.2	575	288.1
	1000	1380	198	325.6	261.7	106.1	609	259.1
	900	1231	199	291.8	215.1	83.9	664	221.2
	800	641	216	165.3	73.0	39.8	700	116.0
	600	288	236	80.9	16.0	20.0	594	51.8
	500	218	237	61.5	9.0	15.8	546	38.1
Prop Demand Curve: P	1200	1380	207	340.5	266.4	126.2	575	288.1
	1000	798	209	198.7	134.7	68.4	568	166.0
	900	582	215	149.4	75.7	46.7	594	119.9
	800	409	225	109.5	38.6	32.1	581	83.5
	600	172	232	47.7	7.7	18.9	376	38.1
	500	100	253	30.1	3.2	15.1	290	27.5

	Engine Speed rpm	Engine Power hp	BSFC lb/hp-hr	Fuel Rate gph	Boost Press in-hg Gauge	Intake Air Flow cfm	Exh Manif Temp °F	Exh Gas Flow cfm
Zone Limit Curve: 1	1200	1651	.335	78.9	71.8	4248	990	9122
	1000	1651	.326	76.7	67.6	3383	1107	8204
	900	976	.344	48.0	30.5	1907	1157	5029
	800	638	.363	33.1	14.0	1197	1157	3256
	600	361	.385	19.8	4.2	699	1031	1748
	500	274	.381	14.9	2.4	551	946	1282
Zone Limit Curve: 2	1200	1750	.337	84.2	0.0	4358	1024	9630
	1000	1750	.326	81.2	0.0	3563	1117	8666
	900	1290	.334	61.4	0.0	2348	1202	6279
	800	703	.360	36.0	0.0	1257	1202	3482
	600	361	.385	19.8	0.0	699	1031	1748
	500	274	.381	14.9	0.0	551	946	1282
Zone Limit Curve: 3	1200	1851	.340	90.0	78.9	4457	1067	10174
	1000	1851	.326	86.0	77.5	3747	1128	9150
	900	1651	.327	77.1	63.7	2963	1227	7812
	800	774	.357	39.4	18.3	1324	1247	3747
	600	361	.385	19.8	4.2	699	1031	1748
	500	274	.381	14.9	2.4	551	946	1282
Zone Limit Curve: 4	1200	1851	.340	90.0	78.9	4457	1067	10174
	1000	1851	.326	86.0	77.5	3747	1128	9150
	900	1651	.327	77.1	63.7	2963	1227	7812
	800	860	.355	43.7	21.6	1406	1292	4097
	600	386	.388	21.4	4.7	706	1101	1829
	500	292	.390	16.2	2.7	558	1015	1345
Max Power Curve: M	1200	1851	.340	90.0	78.9	4457	1067	10174
	1000	1851	.326	86.0	77.5	3747	1128	9150
	900	1651	.327	77.1	63.7	2963	1227	7812
	800	860	.355	43.7	21.6	1406	1292	4097
	600	386	.388	21.4	4.7	706	1101	1829
	500	292	.390	16.2	2.7	558	1015	1345
Prop Demand Curve: P	1200	1851	.340	90.0	78.9	4457	1067	10174
	1000	1070	.344	52.5	39.9	2416	1054	5862
	900	780	.353	39.5	22.4	1649	1101	4234
	800	548	.370	28.9	11.4	1134	1078	2949
	600	231	.381	12.6	2.3	667	709	1345
	500	134	.416	8.0	0.9	533	554	971

Brake Mean Effective Pressure 1891 kPa
Heat Rejection to Coolant (total) 524 kW
Heat Rejection to Aftercooler 418 kW
Heat Rejection to Exhaust (total) 1168 kW
Heat Rejection to Atmosphere from Engine 127 kW

Brake Mean Effective Pressure 274 psi
Heat Rejection to Coolant (total) 2980 btu/min
Heat Rejection to Aftercooler 2372 btu/min
Heat Rejection to Exhaust (total) 6642 btu/min
Heat Rejection to Atmosphere from Engine 7222 btu/min

DIMENSIONS

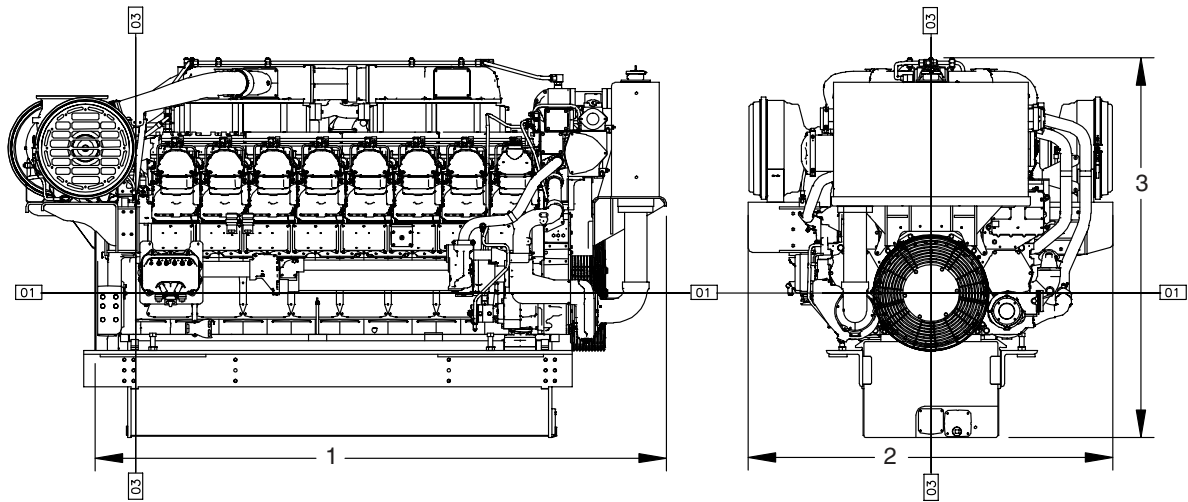

Engine Dimensions		
(1) Length to Flywheel Housing	3185.4 mm	125.4 in.
(2) Width	2036.9 mm	80.19 in.
(3) Height	2123.8 mm	83.6 in.
Weight, Net Dry (approx)	7961-8629 kg	17,550-19,025 lb

Note: Do not use for installation design. See general dimension drawings for detail (#345-7964, #345-7965).

For most current installation drawings, please visit <http://tmi.cat.com>

RATING DEFINITIONS AND CONDITIONS

A Rating (Unrestricted Continuous)

Typical applications: For vessels operating at rated load and rated speed up to 100% of the time without interruption or load cycling (80% to 100% load factor). Typical applications could include but are not limited to vessels such as freighters, tugboats, bottom trawlers, or deep river tugboats. Typical operation ranges from 5000 to 8000 hours per year.

B Rating (Heavy Duty)

Typical applications: For vessels operating at rated load and rated speed up to 80% of the time, or 10 hours out of 12, with some load cycling (40% to 80% load factor). Typical applications could include but are not limited to vessels such as mid-water trawlers, purse seiner, crew and supply boats, ferries, or towboats. Typical operation ranges from 3000 to 5000 hours per year.

C Rating (Maximum Continuous)

Typical applications: For vessels operating at rated load and rated speed up to 50% of the time, or 6 hours out of 12, with cyclical load and speed (20% to 80% load

factor). Typical applications could include but are not limited to vessels such as ferries, harbor tugs, fishing boats, offshore service boats, displacement hull yachts, or short trip coastal freighters. Typical operation ranges from 2000 to 4000 hours per year.

Power at declared engine speed is in accordance with ISO3046-1:2002E. Caterpillar maintains ISO9001:1994/QS-9000 approved engine test facilities to assure accurate calibration of test equipment. Electronically controlled engines are set at the factory at the advertised power corrected to standard ambient conditions. The published fuel consumption rates are in accordance with ISO3046-1.

Fuel rates are based on fuel oil of 35° API [16°C (60°F)] gravity having an LHV of 42 780 kJ/kg (18,390 Btu/lb) when used at 29°C (85°F) and weighing 838.9 g/L (7.001 lb/U.S. gal). Additional ratings may be available for specific customer requirements. Consult your Caterpillar representative for additional information.

Performance data is calculated in accordance with tolerances and conditions stated in this specification sheet and is only intended for purposes of comparison with other manufacturers' engines. Actual engine performance may vary according to the particular application of the engine and operating conditions beyond Caterpillar's control.

Power produced at the flywheel will be within standard tolerances up to 50°C (122°F) combustion air temperature measured at the air cleaner inlet, and fuel temperature up to 52°C (125°F) measured at the fuel filter base. Power rated in accordance with NMMA procedure as crankshaft power. Reduce crankshaft power by 3% for propeller shaft power.

CAT, CATERPILLAR, their respective logos, ADEM, "Caterpillar Yellow" and the POWER EDGE trade dress, as well as corporate and product identity used herein, are trademarks of Caterpillar and may not be used without permission.

3516C



MARINE PROPULSION ENGINE

2161 mhp	(2131 bhp)	1590 bkW
2270 mhp	(2239 bhp)	1670 bkW
2379 mhp	(2346 bhp)	1750 bkW



Image shown may not reflect actual engine

COMPLETE SOLUTIONS FOR YOUR MARINE APPLICATION

- Single-source for support and service
- Industry-leading warranty coverage for factory packaged components
- Global dealer network for service in any location

EFFICIENT OPERATION

- Instrument panel with cold mode start strategy and programmable low idle
- Electronic governing control unit minimizes fuel consumption and monitors engine operating parameters
- Optional alarm and protection system

IMPROVED PERFORMANCE AND FUNCTION

- Advanced combustion design uses the optimum configurations and cylinder geometry
- Enhanced control of fuel injection optimized through crank timing

ENVIRONMENTALLY CONSCIOUS

- Closed crankcase ventilation system and redesigned piston for improved efficiency and lower emissions
- Optimal nozzle geometry and electronic injection control for improved fuel delivery
- EPA Marine Tier 3/IMO Tier II Emissions Compliant

SPECIFICATIONS

V-16, 4-Stroke-Cycle-Diesel

- EPA Marine Tier 3 compliant
- IMO Tier II emissions compliant
- 78.08 L (4765 in³) displacement
- 1600 rpm
- 170 mm (6.69 in) bore x 215 mm (8.46 in) stroke
- Turbocharged-aftercooled aspiration
- Electronically governed A4 ECU
- Heat exchanger or keel cooled
- Refill capacity
 - Lube oil system: 779.8 L (206 gal)
- 1000-hour oil change interval
- Counterclockwise rotation
- SAE No. 00 flywheel and flywheel housing (183 teeth)
- Engine diagnostic system data link messaging

All new 3500C marine EPA Tier 3 capable engines, including both propulsion and auxiliary units, will be required to use a maximum concentration of 20% glycol mixture in the aftercooler circuit. This restriction applies equally to both heat exchanger cooled and keel cooled configurations (box coolers). In the event that specific project needs require higher levels of freeze protection, (lower freeze temperature), please contact ASC to review the specific engine rating and glycol concentration desired.

The jacket water circuit will continue to be capable of operation up to 50% glycol.

DIMENSIONS

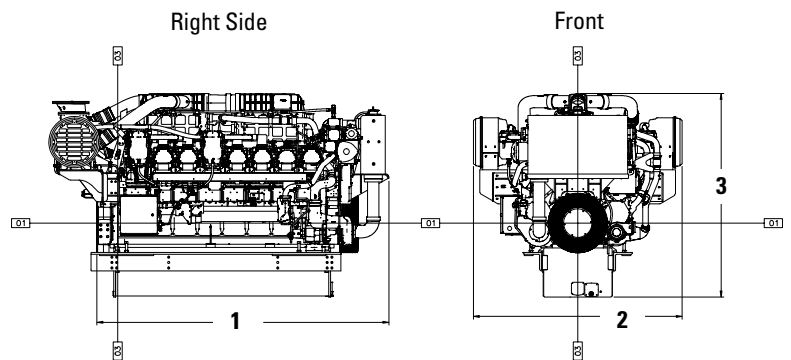

ENGINE DIMENSIONS & WEIGHT

(1) Length to Flywheel Housing	3191.8 mm	125.7 in
(2) Width	2283.8 mm	89.9 in
(3) Height	2224.5 mm	87.6 in
Weight, Net Dry (approx)	9600 kg	21,164 lb

Note: Do not use these dimensions for installation design. See general dimension drawings for detail (Drawing #420-1880). For complete information, please refer to the Marine Spec Sheet Wizard.

MARINE ENGINE PERFORMANCE

rpm	A Rating				B Rating				C Rating			
	bhp	g/hr	bkW	g/bkW-hr	bhp	g/hr	bkW	g/bkW-hr	bhp	g/hr	bkW	g/bkW-hr
1600	2132	103.6	1590	207.0	2240	108.9	1670	207.0	2347	114.1	1750	207.0
1300	2132	100.8	1590	201.3	2240	105.7	1670	201.0	2347	110.8	1750	201.0
1100	1958	89.8	1460	195.3	2012	92.2	1500	195.3	2119	97.2	1580	195.3
900	1021	50.0	761	208.7	1021	50.0	761	208.7	1021	50.0	761	208.7
700	528	26.9	394	216.6	528	26.9	394	216.6	528	26.9	394	216.6
650	471	24.1	351	218.0	471	24.1	351	218.0	471	24.1	351	218.0

rpm	A Rating				B Rating				C Rating			
	bhp	g/hr	bkW	g/bkW-hr	bhp	g/hr	bkW	g/bkW-hr	bhp	g/hr	bkW	g/bkW-hr
1600	2132	103.6	1590	207.0	2240	108.9	1670	207.0	2347	114.1	1750	207.0
1300	1144	56.6	853	210.8	1202	59.5	896	210.9	1259	62.4	939	211.0
1100	693	34.2	517	210.4	728	35.8	543	209.4	763	37.3	569	208.5
900	379	19.3	283	216.6	398	20.2	297	215.5	418	21.0	311	214.5
700	179	9.7	133	231.4	188	10.1	140	229.4	197	10.5	147	227.5
650	143	8.0	107	238.3	150	8.3	112	236.0	157	8.6	117	233.9

STANDARD ENGINE EQUIPMENT

- Corrosion-resistant aftercooler core
- Dual A4 engine control modules w/electronic unit injector fuel system
- Dual turbochargers with water-cooled bearings and heat shields
- Vibration damper and guard
- Closed crankcase ventilation system
- Thermostats and housing
- Electronically cooled unit injectors
- Engine oil cooler and oil filler
- Auxiliary fresh water pump
- Gear-driven, centrifugal jacket water pump
- Oil filter, oil level gauge, and oil pump

OPTIONAL ATTACHMENTS

- Plate-type heat exchanger
- Special appearance packages with chrome cover
- Marine society certifications
- Power takeoff
- Shutoff and alarm contactors
- SOLAS compliant fuel connections with spill shield
- Instrument panel with color Marine Power Display (MPD)
- Mounting rails
- Sea water pump
- See Marine Price List for additional attachments

RATING DEFINITIONS AND CONDITIONS

A Rating (Unrestricted Continuous)

Typical applications: For vessels operating at rated load and rated speed up to 100% of the time without interruption or load cycling (80% to 100% load factor). Typical applications could include but are not limited to vessels such as freighters, tugboats, bottom trawlers, or deep river tugboats. Typical operation ranges from 5000 to 8000 hours per year.

B Rating (Heavy Duty)

Typical applications: For vessels operating at rated load and rated speed up to 80% of the time, or 10 hours out of 12, with some load cycling (40% to 80% load factor). Typical applications could

include but are not limited to vessels such as mid-water trawlers, purse seiner, crew and supply boats, ferries, or towboats. Typical operation ranges from 3000 to 5000 hours per year.

C Rating (Maximum Continuous)

Typical applications: For vessels operating at rated load and rated speed up to 50% of the time, or 6 hours out of 12, with cyclical load and speed (20% to 80% load factor). Typical applications could include but are not limited to vessels such as ferries, harbor tugs, fishing boats, offshore service boats, displacement hull yachts, or short trip coastal freighters. Typical operation ranges from 2000 to 4000 hours per year.

CAT, CATERPILLAR, their respective logos, "Caterpillar Yellow" and the "Power Edge" trade dress, as well as corporate and product identity used herein, are trademarks of Caterpillar and may not be used without permission.

3516C



MARINE PROPULSION ENGINE

2480 mhp	(2446 bhp)	1825 kW
2610 mhp	(2574 bhp)	1920 kW
2712 mhp	(2675 bhp)	1995 kW



Image shown may not reflect actual engine

COMPLETE SOLUTIONS FOR YOUR MARINE APPLICATION

- Single-source for support and service
- Industry-leading warranty coverage for factory packaged components
- Global dealer network for service in any location

EFFICIENT OPERATION

- Instrument panel with cold mode start strategy and programmable low idle
- Electronic governing control unit minimizes fuel consumption and monitors engine operating parameters
- Optional alarm and protection system

IMPROVED PERFORMANCE AND FUNCTION

- Advanced combustion design uses the optimum configurations and cylinder geometry
- Enhanced control of fuel injection optimized through crank timing

ENVIRONMENTALLY CONSCIOUS

- Closed crankcase ventilation system and redesigned piston for improved efficiency and lower emissions
- Optimal nozzle geometry and electronic injection control for improved fuel delivery
- EPA Marine Tier 3/IMO Tier II Emissions Compliant

SPECIFICATIONS

V-16, 4-Stroke-Cycle-Diesel

- EPA Marine Tier 3 compliant
- IMO Tier II emissions compliant
- 78.08 L (4765 in³) displacement
- 1600 rpm
- 170 mm (6.69 in) bore x 215 mm (8.46 in) stroke
- Turbocharged-aftercooled aspiration
- Electronically governed A4 ECU
- Heat exchanger or keel cooled
- Refill capacity
 - Lube oil system: 779.8 L (206 gal)
- 1000-hour oil change interval
- Counterclockwise rotation
- SAE No. 00 flywheel and flywheel housing (183 teeth)
- Engine diagnostic system data link messaging

All new 3500C marine EPA Tier 3 capable engines, including both propulsion and auxiliary units, will be required to use a maximum concentration of 20% glycol mixture in the aftercooler circuit. This restriction applies equally to both heat exchanger cooled and keel cooled configurations (box coolers). In the event that specific project needs require higher levels of freeze protection, (lower freeze temperature), please contact ASC to review the specific engine rating and glycol concentration desired.

The jacket water circuit will continue to be capable of operation up to 50% glycol.

DIMENSIONS

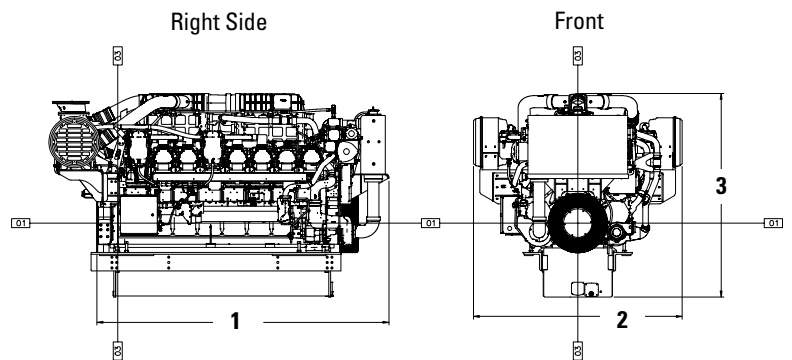

ENGINE DIMENSIONS & WEIGHT

(1) Length to Flywheel Housing	3191.8 mm	125.7 in
(2) Width	2283.8 mm	89.9 in
(3) Height	2224.5 mm	87.6 in
Weight, Net Dry (approx)	9600 kg	21,164 lb

Note: Do not use these dimensions for installation design. See general dimension drawings for detail (Drawing #420-1880). For complete information, please refer to the Marine Spec Sheet Wizard.

MARINE ENGINE PERFORMANCE

rpm	A Rating				B Rating				C Rating			
	bhp	g/hr	bkW	g/bkW-hr	bhp	g/hr	bkW	g/bkW-hr	bhp	g/hr	bkW	g/bkW-hr
1600	2447	118.9	1825	206.9	2575	125.0	1920	206.7	2675	129.8	1995	206.6
1300	2447	115.7	1825	201.3	2575	122.2	1920	202.1	2675	127.5	1995	203.0
1100	2119	97.2	1580	195.3	2119	97.2	1580	195.3	2119	97.2	1580	195.3
900	1021	50.0	761	208.7	1021	50.0	761	208.7	1021	50.0	761	208.7
700	528	26.9	394	216.6	528	26.9	394	216.6	528	26.9	394	216.6
650	471	24.1	351	218.0	471	24.1	351	218.0	471	24.1	351	218

rpm	A Rating				B Rating				C Rating			
	bhp	g/hr	bkW	g/bkW-hr	bhp	g/hr	bkW	g/bkW-hr	bhp	g/hr	bkW	g/bkW-hr
1600	2447	118.9	1825	206.9	2575	125.0	1920	206.7	2675	129.8	1995	206.6
1300	1313	65.1	979	211.1	1381	68.4	1030	210.9	1435	70.9	1070	210.4
1100	795	38.8	593	207.7	837	40.6	624	206.7	869	42.1	648	206.0
900	436	21.9	325	213.7	458	22.9	342	212.9	476	23.7	355	212.4
700	205	10.9	153	226.0	216	11.3	161	224.2	224	11.7	167	222.9
650	164	8.9	122	232.1	173	9.3	129	230.1	179	9.6	134	228.6

STANDARD ENGINE EQUIPMENT

- Corrosion-resistant aftercooler core
- Dual A4 engine control modules w/electronic unit injector fuel system
- Dual turbochargers with water-cooled bearings and heat shields
- Vibration damper and guard
- Closed crankcase ventilation system
- Thermostats and housing
- Electronically cooled unit injectors
- Engine oil cooler and oil filler
- Auxiliary fresh water pump
- Gear-driven, centrifugal jacket water pump
- Oil filter, oil level gauge, and oil pump

OPTIONAL ATTACHMENTS

- Plate-type heat exchanger
- Special appearance packages with chrome cover
- Marine society certifications
- Power takeoff
- Shutoff and alarm contactors
- SOLAS compliant fuel connections with spill shield
- Instrument panel with color Marine Power Display (MPD)
- Mounting rails
- Sea water pump
- See Marine Price List for additional attachments

RATING DEFINITIONS AND CONDITIONS

A Rating (Unrestricted Continuous)

Typical applications: For vessels operating at rated load and rated speed up to 100% of the time without interruption or load cycling (80% to 100% load factor). Typical applications could include but are not limited to vessels such as freighters, tugboats, bottom trawlers, or deep river tugboats. Typical operation ranges from 5000 to 8000 hours per year.

B Rating (Heavy Duty)

Typical applications: For vessels operating at rated load and rated speed up to 80% of the time, or 10 hours out of 12, with some load cycling (40% to 80% load factor). Typical applications could

include but are not limited to vessels such as mid-water trawlers, purse seiner, crew and supply boats, ferries, or towboats. Typical operation ranges from 3000 to 5000 hours per year.

C Rating (Maximum Continuous)

Typical applications: For vessels operating at rated load and rated speed up to 50% of the time, or 6 hours out of 12, with cyclical load and speed (20% to 80% load factor). Typical applications could include but are not limited to vessels such as ferries, harbor tugs, fishing boats, offshore service boats, displacement hull yachts, or short trip coastal freighters. Typical operation ranges from 2000 to 4000 hours per year.

CAT, CATERPILLAR, their respective logos, "Caterpillar Yellow" and the "Power Edge" trade dress, as well as corporate and product identity used herein, are trademarks of Caterpillar and may not be used without permission.

3516C



MARINE PROPULSION ENGINE

3045 mhp	(3003 bhp)	2240 kW
3194 mhp	(3150 bhp)	2350 kW
3432 mhp	(3385 bhp)	2525 kW



Image shown may not reflect actual engine

COMPLETE SOLUTIONS FOR YOUR MARINE APPLICATION

- Single-source for support and service
- Industry-leading warranty coverage for factory packaged components
- Global dealer network for service in any location

EFFICIENT OPERATION

- Instrument panel with cold mode start strategy and programmable low idle
- Electronic governing control unit minimizes fuel consumption and monitors engine operating parameters
- Optional alarm and protection system

IMPROVED PERFORMANCE AND FUNCTION

- Advanced combustion design uses the optimum configurations and cylinder geometry
- Enhanced control of fuel injection optimized through crank timing

ENVIRONMENTALLY CONSCIOUS

- Closed crankcase ventilation system and redesigned piston for improved efficiency and lower emissions
- Optimal nozzle geometry and electronic injection control for improved fuel delivery
- EPA Marine Tier 3/IMO Tier II Emissions Compliant

SPECIFICATIONS

V-16, 4-Stroke-Cycle-Diesel

- EPA Marine Tier 3 compliant
- IMO Tier II emissions compliant
- 78.08 L (4765 in³) displacement
- 1800 rpm
- 170 mm (6.69 in) bore x 215 mm (8.46 in) stroke
- Turbocharged-aftercooled aspiration
- Electronically governed A4 ECU
- Heat exchanger or keel cooled
- Refill capacity
 - Lube oil system: 779.8 L (206 gal)
- 1000-hour oil change interval
- Counterclockwise rotation
- SAE No. 00 flywheel and flywheel housing (183 teeth)
- Engine diagnostic system data link messaging

All new 3500C marine EPA Tier 3 capable engines, including both propulsion and auxiliary units, will be required to use a maximum concentration of 20% glycol mixture in the aftercooler circuit. This restriction applies equally to both heat exchanger cooled and keel cooled configurations (box coolers). In the event that specific project needs require higher levels of freeze protection, (lower freeze temperature), please contact ASC to review the specific engine rating and glycol concentration desired.

The jacket water circuit will continue to be capable of operation up to 50% glycol.

DIMENSIONS

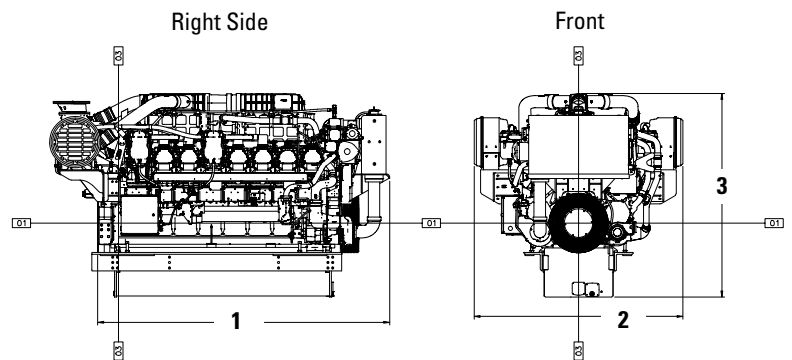

ENGINE DIMENSIONS & WEIGHT

(1) Length to Flywheel Housing	3191.8 mm	125.7 in
(2) Width	2283.8 mm	89.9 in
(3) Height	2224.5 mm	87.6 in
Weight, Net Dry (approx)	9600 kg	21,164 lb

Note: Do not use these dimensions for installation design. See general dimension drawings for detail (Drawing #420-1880). For complete information, please refer to the Marine Spec Sheet Wizard.

MARINE ENGINE PERFORMANCE

rpm	B Rating				C Rating				D Rating			
	bhp	g/hr	bkW	g/bkW-hr	bhp	g/hr	bkW	g/bkW-hr	bhp	g/hr	bkW	g/bkW-hr
1800	3004	147.6	2240	209.2	3151	155.4	2350	209.9	3386	167.4	2525	210.5
1500	3004	141.1	2240	200.0	3151	149.5	2350	202.0	3386	167.4	2525	206.6
1300	2588	116.9	1930	192.3	2682	121.0	2000	192.2	2760	124.5	2058	192.0
1100	1526	71.6	1138	199.9	1526	71.6	1138	199.9	1526	71.6	1138	199.9
900	748	37.6	558	214.3	748	37.6	558	214.3	748	37.6	558	214.3
700	489	24.9	365	216.8	489	24.9	365	216.8	489	24.9	365	216.8

rpm	B Rating				C Rating				D Rating			
	bhp	g/hr	bkW	g/bkW-hr	bhp	g/hr	bkW	g/bkW-hr	bhp	g/hr	bkW	g/bkW-hr
1800	3004	147.6	2240	209.2	3151	155.4	2350	209.9	3386	167.4	2525	210.5
1500	1738	82.5	1296	202.1	1824	86.3	1360	201.5	1959	92.3	1461	200.6
1300	1132	54.4	844	204.6	1187	56.8	885	203.8	1275	60.8	951	202.8
1100	685	34.2	511	212.5	719	35.8	536	211.9	772	38.3	576	210.9
900	375	19.3	280	219.0	394	20.2	294	217.8	424	21.5	316	216.2
700	177	9.7	132	234.2	185	10.1	138	231.9	200	10.7	149	228.8

STANDARD ENGINE EQUIPMENT

- Corrosion-resistant aftercooler core
- Dual A4 engine control modules w/electronic unit injector fuel system
- Dual turbochargers with water-cooled bearings and heat shields
- Vibration damper and guard
- Closed crankcase ventilation system
- Thermostats and housing
- Electronically cooled unit injectors
- Engine oil cooler and oil filler
- Auxiliary fresh water pump
- Gear-driven, centrifugal jacket water pump
- Oil filter, oil level gauge, and oil pump

OPTIONAL ATTACHMENTS

- Plate-type heat exchanger
- Special appearance packages with chrome cover
- Marine society certifications
- Power takeoff
- Shutoff and alarm contactors
- SOLAS compliant fuel connections with spill shield
- Instrument panel with color Marine Power Display (MPD)
- Mounting rails
- Sea water pump
- See Marine Price List for additional attachments

RATING DEFINITIONS AND CONDITIONS

B Rating (Heavy Duty)

Typical applications: For vessels operating at rated load and rated speed up to 80% of the time, or 10 hours out of 12, with some load cycling (40% to 80% load factor). Typical applications could include but are not limited to vessels such as mid-water trawlers, purse seiner, crew and supply boats, ferries, or towboats. Typical operation ranges from 3000 to 5000 hours per year.

C Rating (Maximum Continuous)

Typical applications: For vessels operating at rated load and rated speed up to 50% of the time, or 6 hours out of 12, with cyclical load and speed (20% to 80% load factor). Typical applications could include but are not limited to vessels such as ferries, harbor tugs,

fishing boats, offshore service boats, displacement hull yachts, or short trip coastal freighters. Typical operation ranges from 2000 to 4000 hours per year.

D Rating (Intermittent Duty)

Typical applications: For vessels operating at rated load and rated speed up to 16% of the time, or 2 hours out of 12, (up to 50% load factor). Typical applications could include but are not limited to vessels such as offshore patrol boats, customs boats, police boats, some fishing boats, fireboats, or harbor tugs. Typical operation ranges from 1000 to 3000 hours per year.

CAT, CATERPILLAR, their respective logos, "Caterpillar Yellow" and the "Power Edge" trade dress, as well as corporate and product identity used herein, are trademarks of Caterpillar and may not be used without permission.

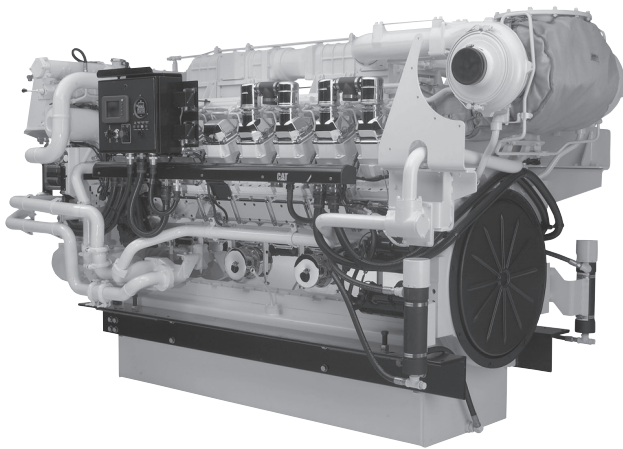

Image shown may not reflect actual engine

SPECIFICATIONS

V-16, 4-Stroke-Cycle-Diesel

Emissions	IMO compliant
Displacement	78.08 L (4764.73 cu. in.)
Rated Engine Speed	1600 rpm
Bore	170.0 mm (6.69 in.)
Stroke	215.0 mm (8.46 in.)
Aspiration	Turbocharged-Aftercooled
Governor	ADEM™ A3
Cooling System	Heat Exchanger
Weight, Net Dry (approx)	10,447 kg (23,032 lb)
Refill Capacity	
Lube Oil System	810.1 L (214 gal)
Caterpillar Diesel Engine Oil	10W30 or 15W40
Rotation (from flywheel end)	Counterclockwise
Flywheel and Flywheel Housing	SAE No. 00
Flywheel Teeth	183

STANDARD ENGINE EQUIPMENT

Air Inlet System

Corrosion-resistant separate circuit aftercooler core, power-core air cleaners with service indicator, dual turbochargers

Control System

Dual A3 engine control modules provide engine control and monitoring, rigid wiring harness with plug and run connectors on port and starboard sides

Cooling System

Separate circuit auxiliary fresh water pump, centrifugal non-self-priming auxiliary sea water pump, gear driven centrifugal jacket water pump, expansion tank, engine oil cooler, thermostats and housing

Exhaust System

Dry gas-tight exhaust manifolds with SOLAS compliant heat shields, dual turbochargers with water-cooled bearings and heat shields, modular pulse exhaust manifold, single exhaust outlet

Fuel System

Electronically controlled unit injectors, fuel filter with service indicators, fuel transfer pump, SOLAS compliant fuel connections with spill shield

Instrumentation

Engine-mounted instrument panel with Marine Power Display (MPD), four-position engine control switch, alarm horn, overspeed shutdown notification light, emergency stop notification light, secondary ECU "Ready" light, secondary ECU "Active" light, graphic display unit for analog or digital display of oil and fuel pressure, oil and fuel filter differential, system DC voltage, exhaust and water temperature, air inlet restriction, service meter, engine speed, fuel consumption (total and instantaneous)

Lube System

Pre-lube strategy, top-mounted dual crankcase breathers, oil filter with service indicators, oil level gauge, oil filler, gear-type oil pump

Mounting System

Mounting rails

Power Take-Offs

Accessory drives — upper RH, upper and lower LH; two-sided front housing

Protection System

A3 electronic control module with customer programmable engine derate strategies, engine alarms and diagnostics displayed on local and remote MPDs, emergency stop pushbutton, safety shutoff protection for oil pressure and water temperature, overspeed protection

General

Vibration damper and guard, Cat® yellow paint, lifting eyes

ISO Certification

Factory-designed systems built at Caterpillar ISO 9001:2000 certified facilities

MARINE ENGINE PERFORMANCE

3516C HD TA
2855 mhp (2816 bhp) 2100 kW @ 1600 rpm
D Rating — DM9256-01

Aftercooler Temperature 43°C (109°F)

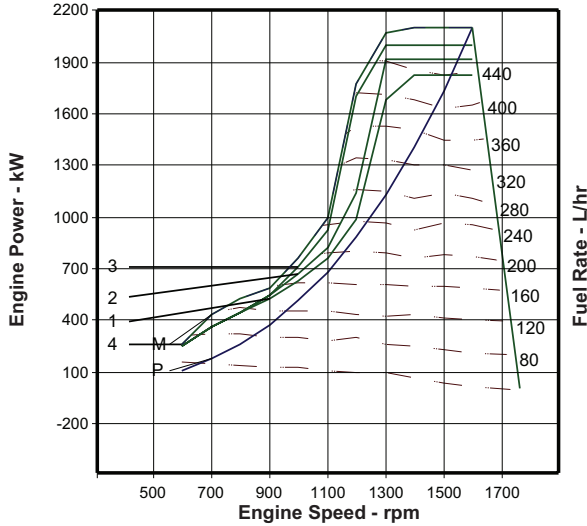

Performance Data

	Speed rpm	Engine Power kW	BSFC g/kW-hr	Fuel Rate L/hr	Boost Press kPa Gauge	Intake Air Flow m³/min	Exh Manif Temp °C	Exh Gas Flow m³/min
Zone Limit	1600	1825	200	434.8	202.7	158.1	571	397.0
Curve: 1	1300	1678	196	392.0	175.2	122.9	628	324.7
	1100	761	213	193.6	43.8	52.5	636	146.2
	900	530	223	140.9	19.4	35.6	638	98.6
	700	365	214	93.2	8.9	24.1	586	64.4
	600	254	213	64.4	4.2	20.3	481	49.6
Zone Limit	1600	1920	199	454.7	202.7	161.7	580	410.1
Curve: 2	1300	1920	193	442.4	175.2	136.4	639	362.1
	1100	821	212	207.7	43.8	55.0	657	156.6
	900	543	224	144.6	19.4	35.9	650	100.8
	700	365	214	93.2	8.9	24.1	586	64.4
	600	254	213	64.4	4.2	20.3	481	49.6
Zone Limit	1600	2000	199	473.2	218.7	165.2	591	423.2
Curve: 3	1300	2000	193	459.1	217.5	141.0	643	374.8
	1100	929	211	233.1	62.6	59.8	686	175.4
	900	543	224	144.6	20.3	35.9	650	100.8
	700	365	214	93.2	8.9	24.1	586	64.4
	600	254	213	64.4	4.2	20.3	481	49.6
Zone Limit	1600	2100	199	498.2	228.5	169.7	606	441.6
Curve: 4	1300	2069	192	473.5	227.0	145.0	646	385.9
	1100	993	210	248.2	70.7	62.9	699	186.7
	900	585	225	156.9	23.6	37.0	687	108.2
	700	434	223	115.4	12.8	25.0	694	73.8
	600	266	213	67.5	4.6	20.4	501	51.0
Max Power	1600	2100	199	498.2	228.5	169.7	606	441.6
Curve: M	1300	2069	192	473.5	227.0	145.0	646	385.9
	1100	993	210	248.2	70.7	62.9	699	186.7
	900	585	225	156.9	23.6	37.0	687	108.2
	700	434	223	115.4	12.8	25.0	694	73.8
	600	266	213	67.5	4.6	20.4	501	51.0
Prop Demand	1600	2100	199	498.2	228.5	169.7	606	441.6
Curve: P	1300	1126	204	274.2	96.2	87.1	598	227.3
	1100	682	215	175.1	36.0	49.3	604	132.6
	900	374	220	98.0	10.3	32.4	488	75.5
	700	176	221	46.4	2.0	23.1	310	42.5
	600	111	226	29.9	0.7	19.9	255	33.8

Brake Mean Effective Pressure 1844 kPa
Heat Rejection to Coolant (total) 631 kW
Heat Rejection to Aftercooler 485 kW
Heat Rejection to Exhaust (total) 1941 kW
Heat Rejection to Atmosphere from Engine 138 kW

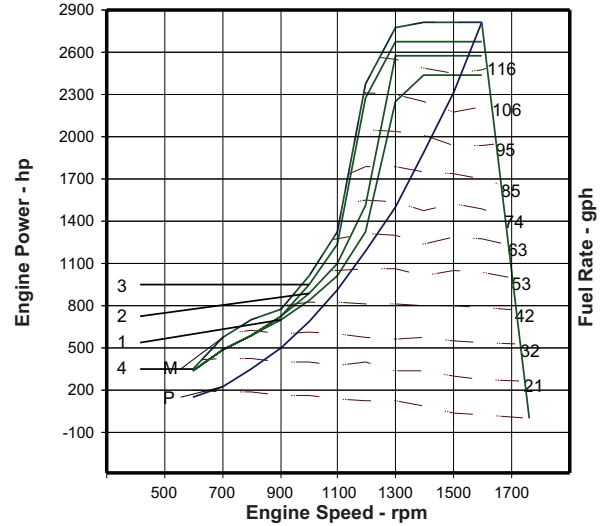

Performance Data

	Speed rpm	Engine Power hp	BSFC lb/hp-hr	Fuel Rate gph	Boost Press in-hg Gauge	Intake Air Flow cfm	Exh Manif Temp °F	Exh Gas Flow cfm
Zone Limit	1600	2447	.329	114.9	60.0	5583	1060	14020
Curve: 1	1300	2250	.322	103.6	51.9	4340	1162	11467
	1100	1021	.350	51.1	13.0	1854	1177	5163
	900	711	.367	37.2	5.7	1257	1180	3482
	700	489	.352	24.6	2.6	851	1087	2274
	600	341	.350	17.0	1.2	717	898	1752
Zone Limit	1600	2575	.327	120.1	60.0	5710	1076	14483
Curve: 2	1300	2575	.317	116.9	51.9	4817	1182	12787
	1100	1101	.349	54.9	13.0	1942	1215	5530
	900	728	.368	38.2	5.7	1268	1202	3560
	700	489	.352	24.6	2.6	851	1087	2274
	600	341	.350	17.0	1.2	717	898	1752
Zone Limit	1600	2682	.327	125.0	64.8	5834	1096	14945
Curve: 3	1300	2682	.317	121.3	64.4	4979	1189	13236
	1100	1246	.347	61.6	18.5	2112	1267	6194
	900	728	.368	38.2	6.0	1268	1202	3560
	700	489	.352	24.6	2.6	851	1087	2274
	600	341	.350	17.0	1.2	717	898	1752
Zone Limit	1600	2816	.327	131.6	67.7	5993	1123	15595
Curve: 4	1300	2775	.316	125.1	67.2	5121	1195	13628
	1100	1332	.345	65.6	20.9	2221	1290	6593
	900	784	.370	41.4	7.0	1307	1269	3821
	700	582	.367	30.5	3.8	883	1281	2606
	600	357	.350	17.8	1.4	720	934	1801
Max Power	1600	2816	.327	131.6	67.7	5993	1123	15595
Curve: M	1300	2775	.316	125.1	67.2	5121	1195	13628
	1100	1332	.345	65.6	20.9	2221	1290	6593
	900	784	.370	41.4	7.0	1307	1269	3821
	700	582	.367	30.5	3.8	883	1281	2606
	600	357	.350	17.8	1.4	720	934	1801
Prop Demand	1600	2816	.327	131.6	67.7	5993	1123	15595
Curve: P	1300	1510	.335	72.4	28.5	3076	1108	8027
	1100	915	.353	46.3	10.7	1741	1119	4683
	900	502	.362	25.9	3.1	1144	910	2666
	700	236	.363	12.3	0.6	816	590	1501
	600	149	.372	7.9	0.2	703	491	1194

Brake Mean Effective Pressure 267 psi
Heat Rejection to Coolant (total) 35885 btu/min
Heat Rejection to Aftercooler 27582 btu/min
Heat Rejection to Exhaust (total) 110384 btu/min
Heat Rejection to Atmosphere from Engine 7848 btu/min

DIMENSIONS

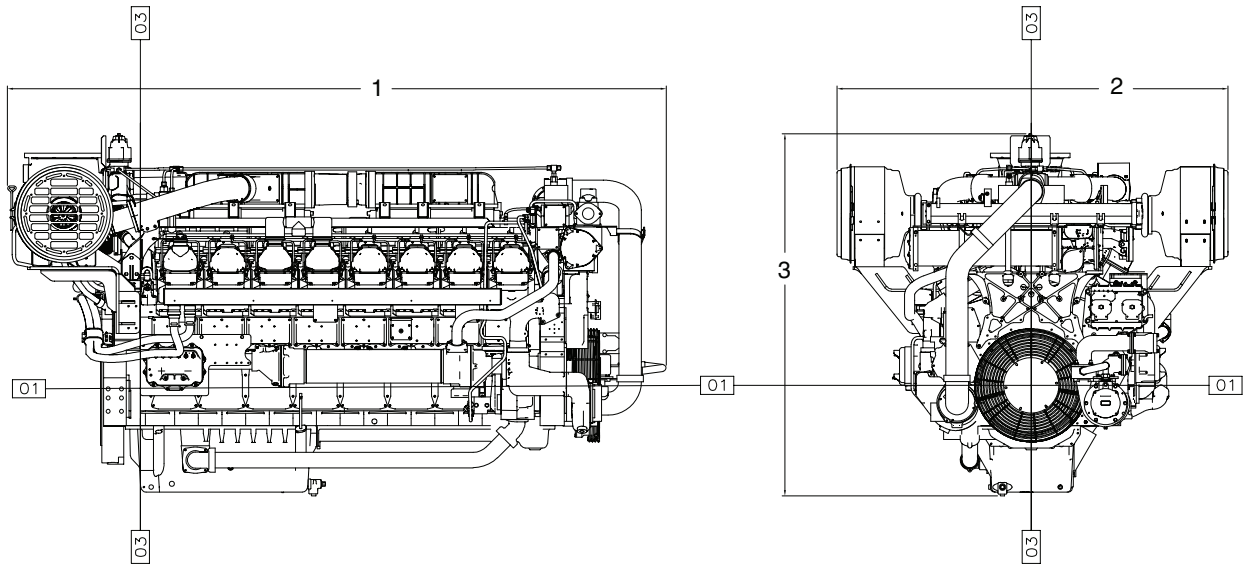

Engine Dimensions		
(1) Length to Flywheel Housing	1184.5 mm	46.63 in.
(2) Width	2159.7 mm	85.03 in.
(3) Height	2129.6 mm	83.84 in.
Weight, Net Dry (approx)	10,447 kg	23,032 lb

Note: Do not use for installation design.
See general dimension drawings
for detail (#310-9297).

RATING DEFINITIONS AND CONDITIONS

D Rating (Intermittent Duty)

Typical applications: For vessels operating at rated load and rated speed up to 16% of the time, or 2 hours out of 12, (up to 50% load factor). Typical applications could include but are not limited to vessels such as offshore patrol boats, customs boats, police boats, some fishing boats, fireboats, or harbor tugs. Typical operation ranges from 1000 to 3000 hours per year.

Power at declared engine speed is in accordance with ISO3046-1:2002E. Caterpillar maintains ISO9001:1994/QS-9000 approved engine test facilities to assure accurate calibration of test equipment. Electronically controlled engines are set at the factory at the advertised power corrected to standard ambient conditions. The published fuel consumption rates are in accordance with ISO3046-1.

Fuel rates are based on fuel oil of 35° API [16°C (60°F)] gravity having an LHV of 42 780 kJ/kg (18,390 Btu/lb) when used at 29°C (85°F) and weighing 838.9 g/L (7.001 lb/U.S. gal). Additional ratings may be available for specific customer requirements. Consult your Cat representative for additional information.

Performance data is calculated in accordance with tolerances and conditions stated in this specification sheet and is only intended for purposes of comparison with other manufacturers' engines. Actual engine performance may vary according to the particular application of the engine and operating conditions beyond Caterpillar's control.

Power produced at the flywheel will be within standard tolerances up to 50°C (122°F) combustion air temperature measured at the air cleaner inlet, and fuel temperature up to 52°C (125°F) measured at the fuel filter base. Power rated in accordance with NMMA procedure as crankshaft power. Reduce crankshaft power by 3% for propeller shaft power.

CAT, CATERPILLAR, their respective logos, ADEM, "Caterpillar Yellow" and the "Power Edge" trade dress, as well as corporate and product identity used herein, are trademarks of Caterpillar and may not be used without permission.